

OPERATOR'S MANUAL

VACMASTER® 15T TIER 4 DIESEL ABRASIVE VACUUMS - JCB

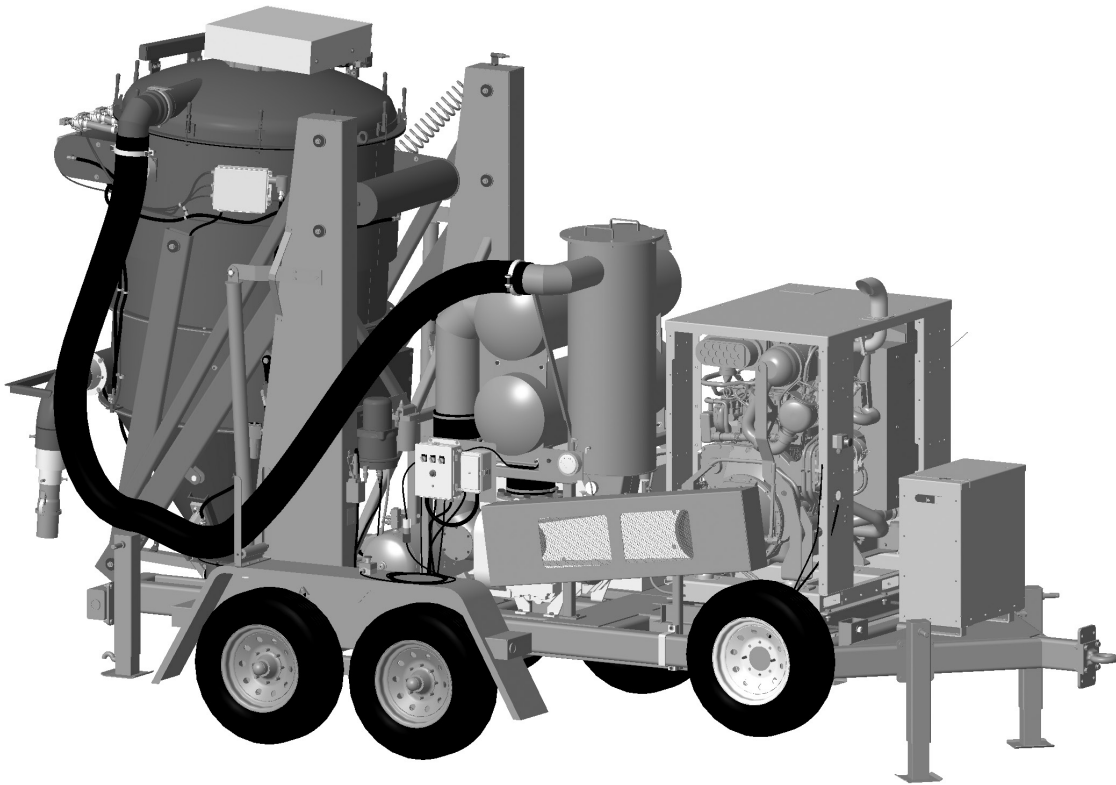

⚠ WARNING

Before using this equipment, read, understand and follow all instructions in the Operator's Manuals provided with this equipment. If the user and/or assistants cannot read or understand the warnings and instructions, the employer of the user and/or assistants must provide adequate and necessary training to ensure proper operation and compliance with all safety procedures pertaining to this equipment. If Operator's Manuals have been lost, please visit www.allredi.com, or contact Allredi at 800.252.7848 for replacements. Failure to comply with the above warning could result in death or serious injury.

ALLREDI™

Company Profile

Allredi was formed in the early 2020, when two of the largest distributors in the blasting, coating, safety, and environmental industry, APE Companies and Marco Group International, joined forces. While the qualities both companies are known for have not changed, a lot about our business is new. New abilities. New agilities. New ways to help you win. This calls for a new name, Allredi.

This name exemplifies what we have become. It is completely oriented to the needs of our customers. To your needs. It says that when you call us for anything – products, service, expert advice, anything – you can consider it done. Or even better, Allredi done.

We are your right-now supplier. From skills to SKUs, we deliver the goods fast. So you can be more agile every minute, every day. This is who we are. This is what our new name means. Go ahead and expect excellence, because we're bringing it.

Our Mission and Vision

To be the industry's preferred partner in surface preparation solutions through unrivaled technical expertise, customer experience, product availability, and tailored service offerings.

The Allredi Difference

- **Industry Experience** – With Allredi on your team, you have access to expertise which can only come from decades of industry leadership. We have organized our engineering department, production specialists, customer operations, and safety support into a "Center of Competence." As an Allredi customer, you have access to hundreds of years of cumulative experience related to your operations.
- **Manufacturing Excellence** – Allredi is a U.S. based manufacturer of equipment for the Surface Preparation and Protective Coatings industries. Allredi's engineers benchmark the industry to ensure that we design and manufacture superior products that set the "Gold Standard" for performance, safety, and quality.
- **Legendary Customer Service** – Allredi's legendary customer service team is staffed by friendly, highly-trained individuals who are focused on providing the highest level of product support, order accuracy, and customer satisfaction.
- **Product Availability** – We stock over 10,000 SKU's and have over 45 shipping locations to serve North American and International markets for all major brands of blasting, coating, environmental, and safety equipment. Allredi is your right-now supplier, so you can keep your projects moving. From our foundation of strong relationships, we have built a nationwide network that puts vast inventory and ready service close to our customers. We provide advanced expertise, and we deliver the goods fast – so you can easily access the products and services you need to me more agile every minute, every day.
- **Technology Leadership** – Our website provides: Operator's Manuals, Part Numbers and Schematics Guides, SDS information, and key product features and specifications, providing access to information 24/7.

TABLE OF CONTENTS

Company Profile	1	Maintenance	23
Definition of Terms	2	Adjust Tension of Blower Drive Belt	23
Air & Abrasive Consumption Chart	6	Adjust Pulse Separation	24
Operating Instructions	9	Remove & Install Blower Drive Belt Assembly	25
Description	9	Remove & Install Filter Bags	27
Operational Requirements	9	Remove & Install Filter Cartridge	28
Towing Safety Instructions	9	Check Lubricator Oil Level	29
Operating Instructions	9	Remove & Install Hopper Access Door Wear Plate	30
Connect Vacuum Hose	12	Hazard Identification Decals	31
Raise and Lower Collection Hopper	13	Troubleshooting	35
Pre-Startup	14	Limited Warranty	38
Unit Startup & Shutdown	15	Disclaimer of Warranty	38
Adjust Vacuum Timer	17	Exclusive Remedy for Warranty Claims	38
Pulser System Startup	18	Limitation of Remedies	38
Reading Magnehelic Gauge	19		
Lubricate Grease Points	20		
Specifications	22		

DEFINITION OF TERMS

DANGER

This is an example of danger. This indicates an imminently hazardous situation which, if not avoided, will result in death or serious injury.

CAUTION

This is an example of a caution. This indicates a potentially hazardous situation which, if not avoided, may result in minor or moderate injury. It can also be used to alert against unsafe practices.

WARNING

This is an example of a warning. This indicates a potentially hazardous situation which, if not avoided, could result in death or serious injury.

NOTICE

This is an example of a notice. This indicates policy or practice directly related to safety of personnel or protection of property.

HAZARD IDENTIFICATIONS

WARNING

Failure to comply with ANY WARNING listed below could result in death or serious injury.

- ▶ OSHA sets exposure limits to protect workers from exposure to respirable crystalline silica, 29 CFR 1910.1053. Airborne dust could increase the exposure levels beyond permissible limits. Breathing dust containing silica could cause silicosis, a fatal lung disease. Breathing dust during abrasive blasting operations, post-blast cleaning operations, and/or servicing equipment within the abrasive blasting area may expose an individual to conditions that could cause asbestosis, lead poisoning and/or other serious or fatal diseases. Harmful dust containing toxic material from abrasives or surfaces being abrasive blasted can remain suspended in the air for long periods of time after abrasive blasting has ceased. A NIOSH-approved, well-maintained, respirator designed for the specific operation being performed must be used by anyone abrasive blasting, handling or using the abrasive, and anyone in the area of the dust.
- ▶ Contact NIOSH and OSHA offices to determine the proper respirator for your specific application. The air supplied to the respirator must be at least Grade D quality as described in Compressed Gas Association Commodity Specification G-7.1 and as specified by OSHA Regulation 1910.134. Ensure air filter and respirator system hoses are not connected to non-air sources or in-plant lines that may contain nitrogen, oxygen, acetylene or other non-breathable gases. Before removing respirator, use an air monitoring instrument to determine if the atmosphere is safe to breathe.
- ▶ You must comply with all OSHA, local, City, State, Province, Country and jurisdiction regulations, ordinances and standards, related to your particular work area and environment. Keep unprotected individuals out of the work area.
- ▶ Abrasive blasting operators must receive thorough training on the use of abrasive resistant attire which includes: supplied-air respirator, abrasive blasting suit, safety shoes, gloves, ear protection and eye protection. Protect the operator and bystanders by complying with NIOSH and OSHA Safety Standards.
- ▶ Inspect all equipment for wear or damage before and after each use. Failure to use Original Equipment Manufacturer repair parts and failure to immediately replace worn or damaged components could void warranties and cause malfunctions.
- ▶ OSHA requires abrasive blasting nozzles be equipped with an operating valve, which shall be designed to be held open only by continuous hand pressure and shall close immediately upon release of hand pressure (i.e., a “deadman” control). The valve shall not be modified in any manner that would allow it to remain open without the application of continuous hand pressure by the operator. Failure to comply with the above warning could result in release of high speed abrasive and compressed air resulting in death or serious injury. OSHA 29CFR 1910.244(b)
- ▶ Point the abrasive blasting nozzle only at the surface being abrasive blasted. Never point the abrasive blasting nozzle or abrasive stream at yourself or others.
- ▶ Unless otherwise specified, maximum working pressure of abrasive blasting pots and related components must not exceed 150 psi. Exceeding maximum working pressure of 150 psi could cause the abrasive blasting pot and components to burst. Failure to comply with the above warning could result in death or serious injury.
- ▶ Never weld, grind or drill on the abrasive blasting pot (or any pressure vessel). Doing so will void ASME certification and manufacturer’s warranty. Welding, grinding or drilling on the abrasive blasting pot (or any pressure vessel) could weaken the vessel causing it to burst. Failure to comply with the above warning could result in death or serious injury. (ASME Pressure Vessel Code, Section VIII, Division 1)
- ▶ This equipment is not intended for use in any area that might be considered a hazardous location, as described in the National Electric Code NFPA 70, Article 500. Use of this equipment in a hazardous location could cause an explosion or electrocution.
- ▶ Never attempt to move an abrasive blasting pot containing abrasive. Never attempt to manually move abrasive blasting pots greater than 6.5 cubic foot capacity. Always use at least two capable people to manually move an abrasive blasting pot on flat, smooth surfaces. A mechanical lifting device must be used if an abrasive blasting pot is moved in any other manner.

HAZARD IDENTIFICATIONS

WARNING

Failure to comply with ANY WARNING listed below could result in death or serious injury.

- ▶ This product is not for use in wet environments. Always use a Ground Fault Interrupter Circuit (GFIC) for all electrical power source connections. Use of this product in wet environments could create a shock or electrocution hazard.
- ▶ Frozen moisture could cause restrictions and obstructions in pneumatic control lines. Any restriction or obstruction in the pneumatic control lines could prevent the proper activation and deactivation of the remote control system, resulting in the release of high speed abrasive and compressed air. In conditions where moisture may freeze in the control lines an antifreeze injection system approved for this application can be installed.
- ▶ Do not cut, obstruct, restrict or pinch pneumatic control lines. Doing so could prevent the proper activation and deactivation of the remote control system, resulting in the release of high speed abrasive and compressed air.
- ▶ Use of Marco remote control switches with other manufacturer's remote control systems could cause unintended activation of remote control systems resulting in the release of high speed abrasive and compressed air. Only Marco remote control switches should be used with Marco remote control systems.
- ▶ Always be certain to have secure footing when abrasive blasting. There is a recoil hazard when abrasive blasting starts that may cause user to fall and misdirect the abrasive stream at operator or bystander.
- ▶ Never use an abrasive blasting pot or attachments as a climbing device. The person could slip and fall. The abrasive blasting pot could become unstable and tip over.
- ▶ For equipment manufactured by entities other than Allredi, you must consult the Original Equipment Manufacturer operator's manuals, information, training, instructions and warnings, for the proper and intended use of all equipment.
- ▶ Flammable fumes, such as solvent and paint fumes in the work area can present an ignition or explosion hazard if allowed to collect in adequate concentrations. To reduce conditions that could result in a fire or an explosion, provide adequate ventilation, eliminate all ignition or spark sources, keep the work area free of debris, store solvents and solvent contaminated rags in approved containers, follow proper grounding procedures, do not plug/unplug power cord or turn on/off power switches when flammable fumes are present, keep a working fire extinguisher or provide another fire suppression system in the work area. Cease all operations and correct condition if a spark or ignition source is identified during operation.
- ▶ Always depressurize the entire system, disconnect all power sources and lockout/tagout all components before any maintenance or troubleshooting is attempted. Failure to comply with the above warning could cause electrical shock and inadvertent activation of equipment resulting in death or serious injury.
- ▶ Moving parts can present an area where crushing, pinching, entanglement or amputation may occur. Do not place body parts or foreign objects in any area where there are moving parts.
- ▶ Surfaces of heated supply tanks, drums and/or lines as well as the adjoining plumbing may become hot during normal use. Do not touch these heated surfaces without proper protection. Deactivate and allow sufficient time for all surfaces to cool before attempting any maintenance.
- ▶ High-pressure fluid from gun, hose leaks, or ruptured components can pierce skin and can cause a serious injury that may result in amputation. Do not point gun or spray tip at anyone or at any part of the body. Keep clear of any leaks or ruptures. Depressurize the entire system before attempting cleaning, inspecting, or servicing equipment.
- ▶ Exposure to toxic fluids or fumes may occur during the normal operation of this system. Before attempting to fill, use, or service this system, read SDS's to know the specific hazards of the fluids you are using. Always use proper Personal Protective Equipment when attempting to fill, use, or service this system.
- ▶ The use of this product for any purpose other than originally intended or altered from its original design is prohibited.
- ▶ Never hang objects from the abrasive blasting pot handle. Doing so may cause the abrasive blasting pot to become unstable and tip over.

HAZARD IDENTIFICATIONS

CAUTION

Failure to comply with ANY CAUTION listed below may result in minor or moderate injury.

- ▶ Static electricity can be generated by abrasive moving through the abrasive blasting hose causing a shock hazard. Prior to use, ground the abrasive blasting pot and abrasive blasting nozzle to dissipate static electricity.
- ▶ High decibel noise levels are generated during the abrasive blasting process which may cause loss of hearing. Ensure appropriate Personal Protective Equipment and hearing protection is in use.

NOTICE

Failure to comply with ANY NOTICE listed below could pose a hazard to personnel or property.

- ▶ See Air & Abrasive Consumption Chart for estimated abrasive consumption rates and required air flow (cubic feet per minute). Your system must meet these minimum requirements to ensure proper function and performance.
- ▶ Always use abrasive that is dry and properly screened. This will reduce the potential for obstructions to enter the remote control system, abrasive metering valve and abrasive blasting nozzle.
- ▶ Moisture build-up occurs when air is compressed. Any moisture within the abrasive blasting system will cause abrasive to clump, clogging metering valves, hoses and nozzles. Install an appropriately sized moisture separator at the inlet of the abrasive blasting system. Leave the moisture separator petcock slightly open to allow for constant release of water. If insufficient volume of air exists and petcock is unable to be left open (at all times) petcock should be opened frequently to release water.
- ▶ To reduce abrasive intrusion in the air supply hose, depressurize the abrasive blasting pot before shutting off air supply from compressor.
- ▶ Inspect abrasive blasting nozzle before placing into service. Damage to abrasive blasting nozzle liner or jacket may occur during shipping. If you receive a damaged abrasive blasting nozzle, contact your distributor immediately for replacement. Abrasive blasting nozzles placed into service may not be returned. Abrasive blasting nozzle liners are made of fragile materials and can be damaged by rough handling and striking against hard surfaces. Never use a damaged abrasive blasting nozzle.
- ▶ Abrasive blasting at optimal pressure for the abrasive used is critical to productivity. Example: For an abrasive with an optimal abrasive blasting pressure of 100 psi at the abrasive blasting nozzle, one pound per square inch of pressure loss will reduce abrasive blasting efficiency by 1.5%. A 10 psi reduction in air pressure will cause a 15% loss of efficiency. Use a Needle Pressure Gauge to identify pressure drops in your system. Consult with your abrasive supplier for the requirements of your abrasive.
- ▶ Replace abrasive blasting nozzle if liner or jacket is cracked or damaged. Replace abrasive blasting nozzle if original orifice size has worn 1/16" or more. Determine abrasive blasting nozzle wear by inserting a drill bit 1/16" larger than original size of abrasive blasting nozzle orifice. If the drill bit passes through abrasive blasting nozzle, replacement is needed.

AIR & ABRASIVE CONSUMPTION CHART

NOTICE

Failure to comply with ANY NOTICE listed below could pose a hazard to personnel or property.

- ▶ See Air & Abrasive Consumption Chart for estimated abrasive consumption rates and required air flow (cubic feet per minute). Your system must meet these minimum requirements to ensure proper function and performance.
- ▶ When it comes to air & abrasive mixtures, more is not necessarily better. Optimum abrasive blasting efficiency takes place when a lean air & abrasive mixture is used. To correctly set the abrasive metering valve, begin with the valve fully closed and slowly increase the amount of abrasive entering the airstream. As you increase the abrasive flow, watch for a “blue flame” at the exit of the abrasive blasting nozzle. Faster cutting, reduced abrasive consumption and lower clean up costs, are benefits of the “blue flame”.
- ▶ Abrasive blasting at optimal pressure for the abrasive used is critical to productivity. Example: For an abrasive with an optimal abrasive blasting pressure of 100 psi at the abrasive blasting nozzle, one pound per square inch of pressure loss will reduce abrasive blasting efficiency by 1.5%. A 10 psi reduction in air pressure will cause a 15% loss of efficiency. Use a Needle Pressure Gauge to identify pressure drops in your system. Consult with your abrasive supplier for the requirements of your abrasive.

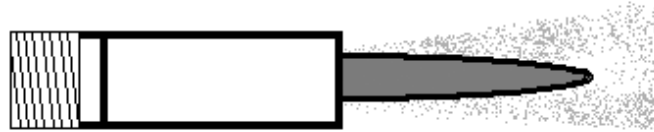

“Blue Flame”

NOTICE

Inspect abrasive blasting nozzle before placing into service. Damage to abrasive blasting nozzle liner or jacket may occur during shipping. If you receive a damaged abrasive blasting nozzle, contact your distributor immediately for replacement. Abrasive blasting nozzles placed into service may not be returned. Abrasive blasting nozzle liners are made of fragile materials and can be damaged by rough handling and striking against hard surfaces. Never use a damaged abrasive blasting nozzle.

Air & Abrasive Consumption Chart*

Nozzle Orifice	Pressure at the Nozzle (PSI)								Air (in cfm), Abrasive & Compressor Requirements
	50	60	70	80	90	100	125	140	
No. 2 (1/8")	11	13	15	17	18	20	25	28	Air (cfm)
	67	77	88	101	112	123	152	170	Abrasive (lbs/hr)
	2.5	3	3.5	4	4.5	5	5.5	6.2	Compressor Horsepower
No. 3 (3/16")	26	30	33	38	41	45	55	62	Air (cfm)
	150	171	196	216	238	264	319	357	Abrasive (lbs/hr)
	6	7	8	9	10	10	12	13	Compressor Horsepower
No. 4 (1/4")	47	54	61	68	74	81	98	110	Air (cfm)
	268	312	354	408	448	494	608	681	Abrasive (lbs/hr)
	11	12	14	16	17	18	22	25	Compressor Horsepower
No. 5 (5/16")	77	89	101	113	126	137	168	188	Air (cfm)
	468	534	604	672	740	812	982	1100	Abrasive (lbs/hr)
	18	20	23	26	28	31	37	41	Compressor Horsepower
No. 6 (3/8")	108	126	143	161	173	196	237	265	Air (cfm)
	668	764	864	960	1052	1152	1393	1560	Abrasive (lbs/hr)
	24	28	32	36	39	44	52	58	Compressor Horsepower
No. 7 (7/16")	147	170	194	217	240	254	314	352	Air (cfm)
	896	1032	1176	1312	1448	1584	1931	2163	Abrasive (lbs/hr)
	33	38	44	49	54	57	69	77	Compressor Horsepower
No. 8 (1/2")	195	224	252	280	309	338	409	458	Air (cfm)
	1160	1336	1512	1680	1856	2024	2459	2754	Abrasive (lbs/hr)
	44	50	56	63	69	75	90	101	Compressor Horsepower
No. 10 (5/8")	308	356	404	452	504	548	663	742	Air (cfm)
	1875	2140	2422	2690	2973	3250	3932	4405	Abrasive (lbs/hr)
	68.5	79.5	90	100.5	112	122	146	165	Compressor Horsepower
No. 12 (3/4")	432	504	572	644	692	784	948	1062	Air (cfm)
	2672	3056	3456	3840	4208	4608	5570	6238	Abrasive (lbs/hr)
	96	112	127	143	154	174.5	209	236	Compressor Horsepower

*Abrasive consumption is based on abrasive with a bulk density of 100 lbs per Cubic Foot

NOTICE

Replace abrasive blasting nozzle if liner or jacket is cracked or damaged. Replace abrasive blasting nozzle if original orifice size has worn 1/16" or more. Determine abrasive blasting nozzle wear by inserting a drill bit 1/16" larger than original size of abrasive blasting nozzle orifice. If the drill bit passes through abrasive blasting nozzle, replacement is needed.

“THE BIG PICTURE”

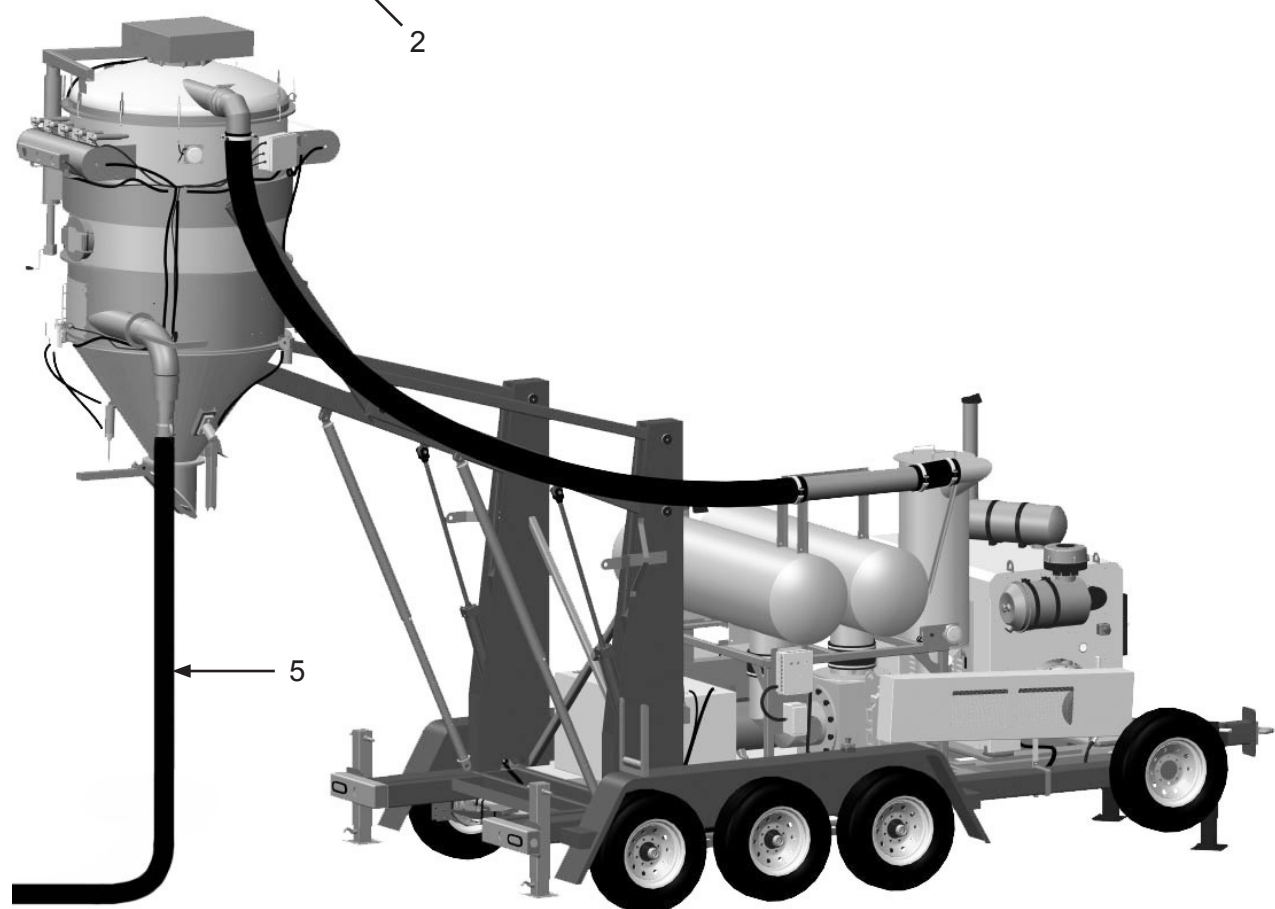
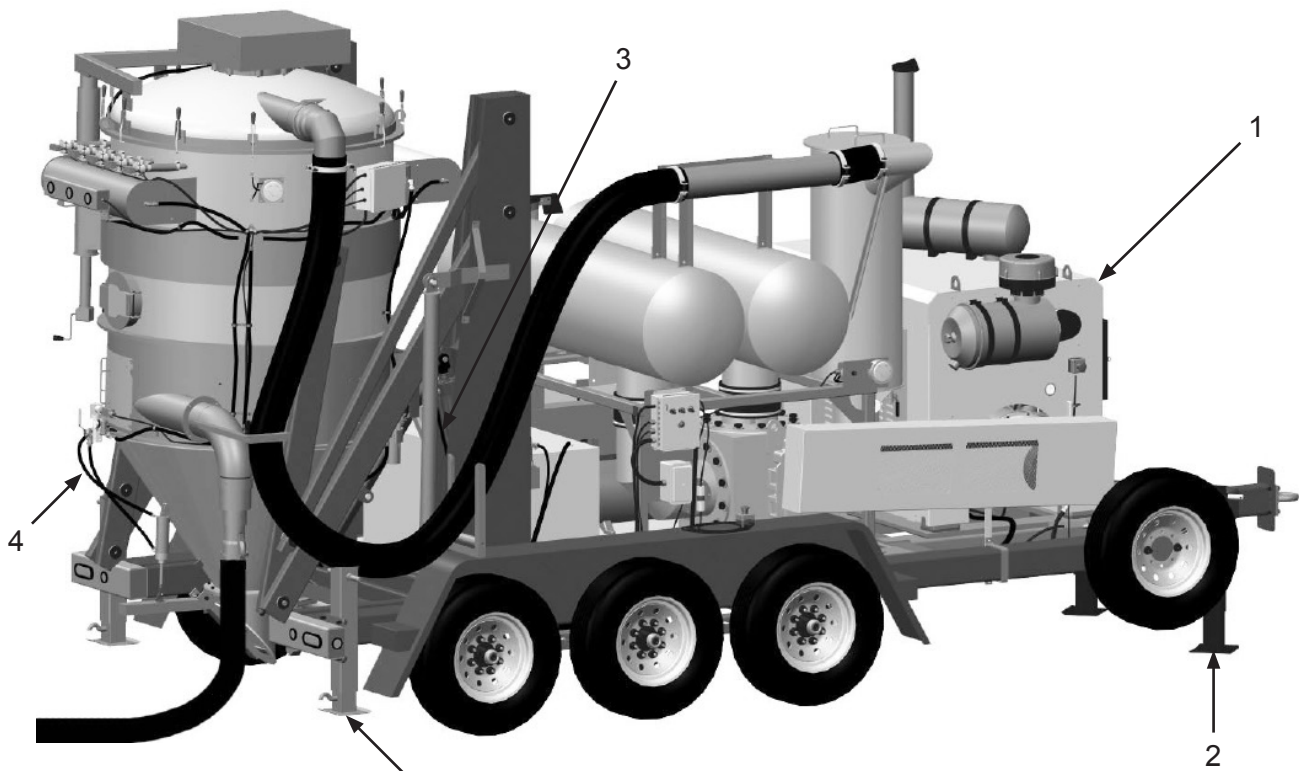

DAILY PRE-OPERATION CHECKLIST

Daily Pre-operation Checklist

- 1. Vacuum
- 2. Jack Stands
- 3. Hydraulic Lines
- 4. Air Lines
- 5. Vacuum Hose

** Optional or alternative device.
Ask your Marco Representative
for more details.*

Vacuum – Position Vacuum (1) as close to the work area as possible. Ensure the surface is level, stable, and is sufficient to support the weight of the unit. Block trailer wheels (if equipped) to prevent unintended movement. Level trailer (if equipped) by adjusting height using four Jack Stands (2) so that it is sitting no more than 5 degrees off level in any direction. Ground machine to a suitable ground. Perform daily lubrication. (See Lubricate Grease Points.) Check all fluid levels.

Air Lines and Hydraulic Lines, – Inspect all Air Lines (4) and Hydraulic Lines (3) for damage or wear. Repair or replace damaged or worn components.

Vacuum Hose – Ensure Vacuum Hose (5) is serviceable and secured to Vacuum. (See Connect Vacuum Hose).

OPERATING INSTRUCTIONS

DANGER

D-506

Do not move vacuum while hopper is in raised position. Failure to comply with the above danger will result in death or serious injury.

WARNING

W-575

Ensure the surface is level, stable, and is sufficient to support the weight of the Device or System. Uneven or unstable surfaces, and/or surfaces that cannot support the gross weight of the Device or System could cause the Device or System to overturn. Failure to comply with the above warning could result in death or serious injury.

WARNING

W-601

Ground machine to a suitable ground before operation. Static discharge could result in a fire or an explosion. Failure to comply with above warning could result in death or serious injury.

WARNING

W-503

You must comply with all OSHA, local, City, State, Province, Country and jurisdiction regulations, ordinances and standards, related to your particular work area and environment. Keep unprotected individuals out of the work area. Failure to comply with the above warning could result in death or serious injury.

Description

The Vacmaster® 15T Tier 4 Diesel Abrasive Vacuums are a trailer mounted vacuum designed to convey granulated materials from a work area to a container for recycling or disposal. Using a powerful 174 HP JCB Tier 4 Final diesel engine to drive the rotary lobe blower, the Vacmaster® 15T Tier 4 Diesel Abrasive Vacuums easily create 27" Hg of suction to quickly move large quantities of material from inside tanks, ship hulls, and containment areas, reducing clean up time on work sites. The large hopper with automatic direct dump gate can be raised and lowered to match the height of your disposal container. The Vacmaster® 15T Tier 4 Diesel Abrasive Vacuums can easily clean up surface preparation work sites of spent abrasives like garnet, coal slag, cooper slag, crushed glass, steel shot, steel grit, and aluminum oxide. Typical applications include blast yards, bridges, oil refineries, pipelines, shipyards, storage tanks, and water treatment plants.

Operational Requirements

This equipment is self-contained and powered by a Diesel engine. It will provide excellent service if properly maintained. There are no unique or complicated parts that require sophisticated maintenance procedures under normal operation. The diesel engine is equipped with automatic shutdowns for low oil pressure and high temperature.

The following may cause safety hazards or reduced performance:

- Improper installation and/or maintenance of components.
- Failing to properly secure unit from movement when not in transport.
- Exceeding 55 mph speed limit when towing unit.
- Operating the Vacmaster® 15T Tier 4 Diesel Abrasive Vacuums under electrical wires or near power cables of any kind.
- Raising the hopper without all four jack stands lowered and pinned.
- Standing under the raised Hopper without support struts pinned in place.

Towing Safety Instructions

- Due to the height of 11'2", extra caution is required for overhead clearance.
- Do not ship or transport via semi-truck trailer. The Vacmaster® 15T Tier 4 Diesel Abrasive Vacuums must be towed behind an appropriate motor vehicle.
- Be sure all lights on the trailer are functioning properly before traveling with this unit.
- Always tow the Vacmaster® 15T Tier 4 Diesel Abrasive Vacuums with the safety chains and the emergency brake cable attached to the towing vehicle.
- Before towing the Vacmaster® 15T Diesel Abrasive Vacuum, inspect the tires and the hitch mechanism for damage.
- Always tow the Vacmaster® 15T Tier 4 Diesel Abrasive Vacuums with the Hopper in the lowered and locked position.
- Always tow the Vacmaster® 15T Tier 4 Diesel Abrasive Vacuums with the Hopper completely empty and the discharge door secured in closed position.
- Tow vehicle must have electric brake controller.
- Do not exceed 55 mph speed limit.

Operating Instructions

Before use:

- Ensure the surface is level, stable, and is sufficient to support the weight of the unit. Block wheels to prevent unintended movement.
- Level Vacmaster® 15T Tier 4 Diesel Abrasive Vacuums by adjusting height using four Jack Stands (1) so that it is sitting no more than 5 degrees off level in any direction.

OPERATING INSTRUCTIONS

⚠ WARNING

W-520

The use of this product for any purpose other than originally intended or altered from its original design is prohibited. Failure to comply with the above warning could result in death or serious injury.

⚠ WARNING

W-505

Inspect all equipment for wear or damage before and after each use. Failure to use Original Equipment Manufacturer repair parts and failure to immediately replace worn or damaged components could void warranties and cause malfunctions. Failure to comply with the above warning could result in death or serious injury.

⚠ WARNING

W-596

Do not place any part of body into or over any suction inlet of vacuum or connected hose. Failure to comply with the above warning could result in death or serious injury.

⚠ WARNING

W-600

Do not use vacuum with hopper in raised position with winds greater than 28 MPH. Unit can tip over. Failure to comply with above warning could result in death or serious injury.

⚠ WARNING

W-599

Do not raise hopper unless area around and above unit is inspected and found to be free of electrical wires or other obstructions. Failure to comply with above warning could result in death or serious injury.

Before use (Cont.)

- Ground machine to a suitable ground.
- Perform daily lubrication. See Lubricate Grease Points.
- Connect vacuum hose. See Connect Vacuum Hose.
- Run vacuum hose and E-Stop Pendant (3) to suction site.
- Close Ball Valves (2).
- Raise collection hopper to working height. See Raise and Lower Collection Hopper.

During use:

- Monitor all fluid levels.
- Monitor air pressure.
- Monitor vacuum pressure
- Monitor both Magnehelic gauges.
- Monitor amount of material collected in catch container to prevent overflowing.

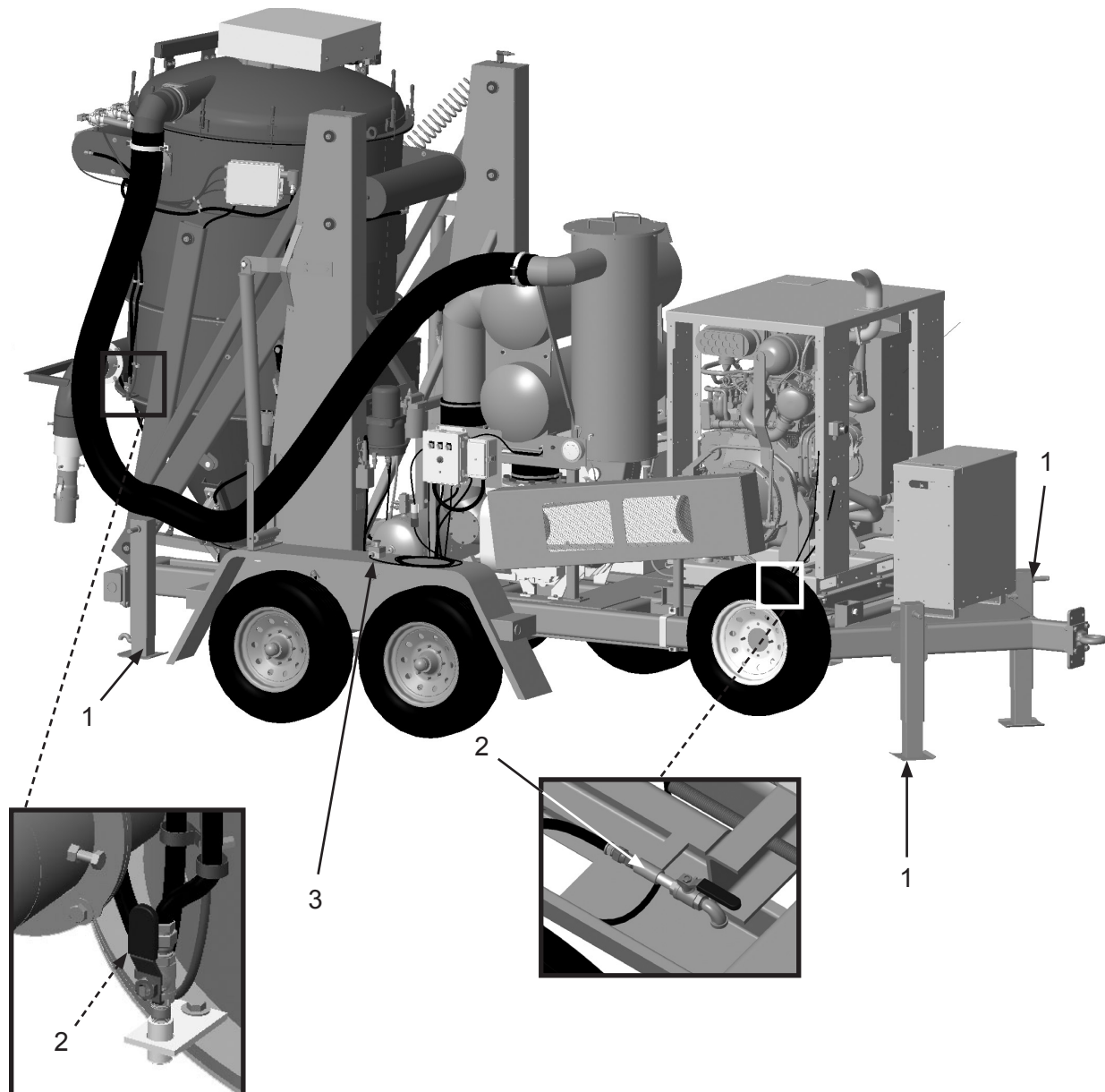

OPERATING INSTRUCTIONS

WARNING

W-505

Inspect all equipment for wear or damage before and after each use. Failure to use Original Equipment Manufacturer repair parts and failure to immediately replace worn or damaged components could void warranties and cause malfunctions. Failure to comply with the above warning could result in death or serious injury.

WARNING

W-596

Do not place any part of body into or over any suction inlet of vacuum or connected hose. Failure to comply with the above warning could result in death or serious injury.

WARNING

W-511

For equipment manufactured by entities other than Marco, you must consult the Original Equipment Manufacturer operator's manuals, information, training, instructions and warnings, for the proper and intended use of all equipment. Failure to comply with the above warning could result in death or serious injury.

NOTICE

N-536

When a dust collector is used to service a storage tank, ensure there is adequate ventilation to prevent tank collapse due to pressure imbalance between external and internal tank surfaces. Failure to properly ventilate storage tank may result in damage to property. If proper ventilation is in question, consult with tank manufacturer or engineer.

After use:

- See Unit Shutdown Instructions.
- Lower collection hopper. See Raise and Lower Collection Hopper.

Note: Allow diesel engine to idle for at least 5 minutes after it has been under load before shutting off.

- Shut unit down.
- Open Pulser System Ball Valve (1).
- Disconnect vacuum hose (*not shown*) from Inlet Port (2).

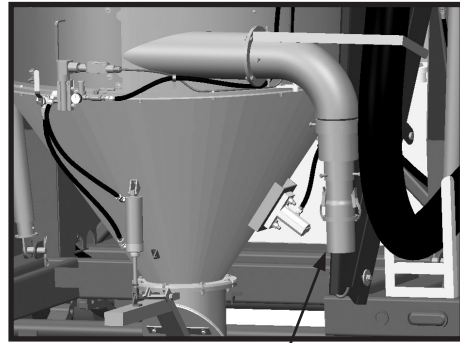

2

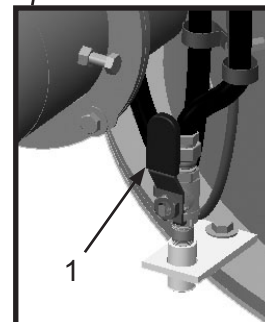
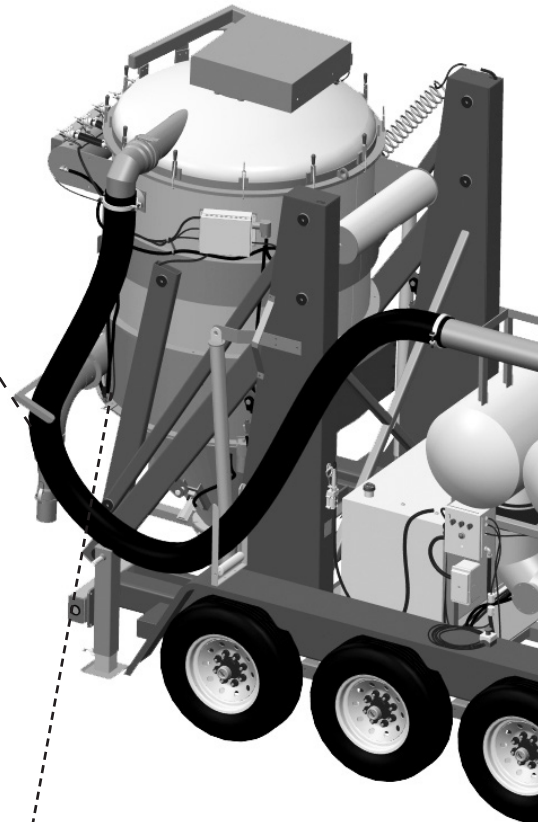

1

OPERATING INSTRUCTIONS

Connect Vacuum Hose

Note: Do not attach hose to vacuum inlet port while machine is running.

- 1) Ensure unit is off.
- 2) Attach Vacuum Hose (*not shown*) to Inlet Port (1).
- 3) Secure with Quick Disconnect Coupling (2).

WARNING

W-562

Always depressurize the entire system, disconnect all power sources and lockout/tagout all components before any maintenance or troubleshooting is attempted. Failure to comply with the above warning could cause electrical shock and inadvertent activation of equipment resulting in death or serious injury.

WARNING

W-596

Do not place any part of body into or over any suction inlet of vacuum or connected hose. Failure to comply with the above warning could result in death or serious injury.



1

2

OPERATING INSTRUCTIONS

Raise and Lower Collection Hopper

⚠ DANGER

D-504

Do not raise hopper unless vacuum is on a level surface and jack stands are down and secured using a proper device. Failure to comply with the above danger will result in death or serious injury.

⚠ DANGER

D-505

Do not leave hopper in raised position without support strut in place and secured using a proper device. Failure to comply with the above danger will result in death or serious injury.

⚠ WARNING

W-599

Do not raise hopper unless area around and above unit is inspected and found to be free of electrical wires or other obstructions. Failure to comply with above warning could result in death or serious injury.

⚠ WARNING

W-597

Always install safety struts when collection hopper is in raised position. Do not stand under collection hopper or between collection hopper and trailer when hydraulic cylinders are in raised position without support struts secured in place. Failure to comply with the above warning could result in death or serious injury.

Note: Do not leave the collection cylinder in the raised position without the support struts pinned in place.

- 1) Power up the unit. See Unit Startup and Shutdown.
- 2) Push "RAISE" Button (1), to raise collection hopper to about five feet above base.
- 3) Remove Pin (2) and pivot Support Strut (3) to Pin Hole (4) and insert pin. Repeat for opposite side.
- 4) Continue raising hopper to sufficient height to clear the collection device. When the proper height is reached, place Support Strut Pin (5) in the closest hole on the Support Struts (3). Repeat for opposite side.
- 5) Push "LOWER" Button (6), to gradually lower the hopper until it is resting on Support Strut Pins (5).
- 6) Reverse procedure to lower collection hopper.

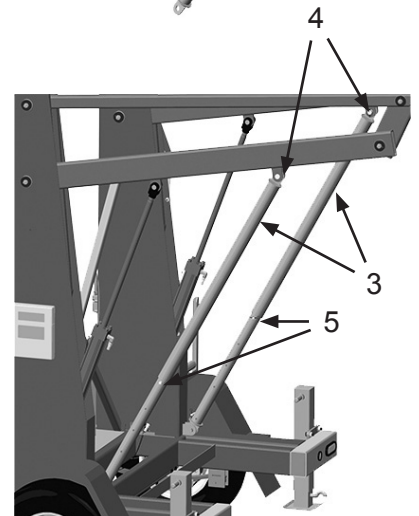
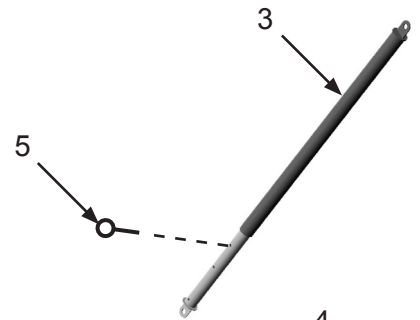
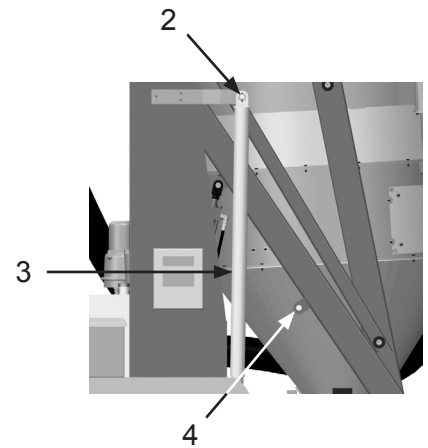
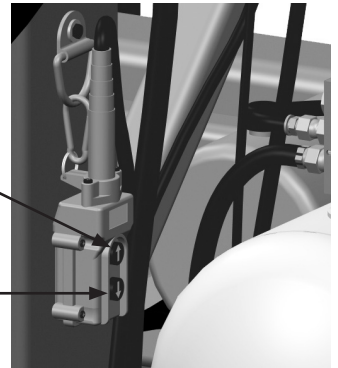

OPERATING INSTRUCTIONS

Pre-Startup

WARNING

W-587

Escaping fluid under pressure can penetrate skin and tissue causing injury. Stop pump and relieve pressure before attempting maintenance or repair. Ensure all fittings are properly tightened before restoring pressure. If injury should occur, immediately seek medical attention. Failure to comply with the above warning could result in death or serious injury.

WARNING

W-566

Exposure to toxic fluids or fumes may occur during the normal operation of this system. Before attempting to fill, use, or service this system, read SDS's to know the specific hazards of the fluids you are using. Always use proper Personal Protective Equipment when attempting to fill, use, or service this system. Failure to comply with the above warning could result in death or serious injury.

Pre-Startup Instructions:

- 1) Check engine oil and coolant levels. See Engine Operator's Manual for instructions.
- 2) Check diesel fuel level using fuel gauge on fuel tank. Add diesel fuel, as needed.
- 3) Check hydraulic oil level using Dip Stick (1) on Hydraulic Oil Tank (2). Add hydraulic oil, as needed.
- 4) Check Engine Control Panel for DEF level. Add DEF, as needed.

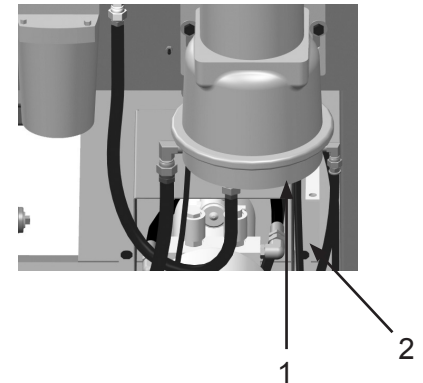

OPERATING INSTRUCTIONS

Unit Startup & Shutdown

DANGER

Do not vacuum flammable or combustible material. An explosion is possible. Failure to comply with the above warning will result in death or serious injury.

WARNING

Do not place any part of body into or over any suction inlet of vacuum or connected hose. Failure to comply with the above warning could result in death or serious injury.

CAUTION

High decibel noise levels are generated during the vacuum process which may cause loss of hearing. Ensure appropriate hearing protection is in use. Failure to comply with the above caution may result in minor or moderate injury.

Unit Startup Instructions:

- 1) Ensure Clutch Handle (4) is disengaged.
- 2) Turn Key (1) "ON". Wait for screen to read "Power Up"
- 3) Press far left button (2) to start.

Note: Ensure that personnel are away from inlet duct opening.

Note: Rapid engagement of clutch may cause damage to clutch and belts to slip from pulleys.

- 4) Slowly engage clutch until fully engaged and handle is in its locked position.
- 5) On Vacuum Control Box (5), turn Vacuum Selector Switch (6) "ON".
- 6) Check Air Pressure Gauge (3) for 90-95 psi of air.
- 7) Start pulser system. See Pulser System Startup.
- 8) Adjust vacuum timer. See Adjust Vacuum Timer.
- 9) Turn Vibrator Selector Switch (8) "ON".
- 10) Ensure Pulse Selector Switch (7) is "ON".

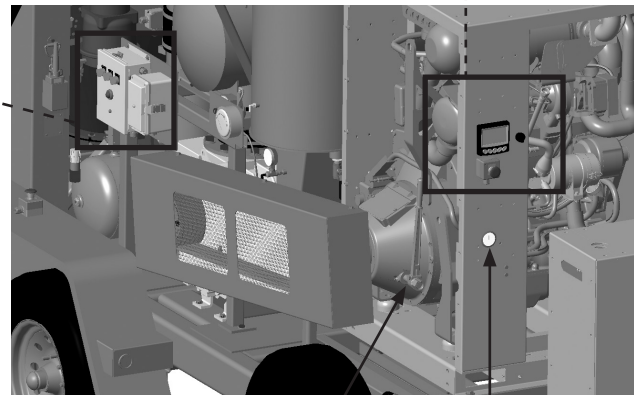
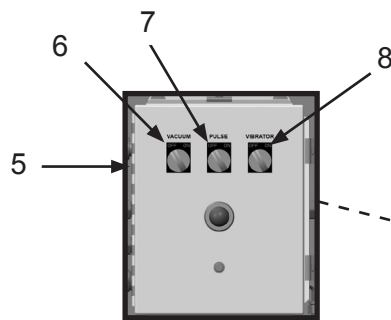

OPERATING INSTRUCTIONS

Unit Startup & Shutdown (Cont.)

Unit Shutdown Instructions:

Note: In the event of an emergency, press one of the Emergency-Stop Stations to cease operation of the system.

- 1) Allow all material to clear suction hose.
- 2) On Vacuum Control Box (5), decrease engine speed to Idle by turning Vacuum Selector Switch (5) "OFF".
- 3) Disengage Clutch Handle (4).
- 4) Turn Vibrator Selector Switch (8) "OFF".
- 5) Turn Pulse Selector Switch (7) "OFF".
- 6) Press far left button (2) under red emblem to stop.
- 7) Turn Key (1) to "Off".
- 8) Follow After Use instructions.

WARNING

W-503

You must comply with all OSHA, local, City, State, Province, Country and jurisdiction regulations, ordinances and standards, related to your particular work area and environment. Keep unprotected individuals out of the work area. Failure to comply with the above warning could result in death or serious injury.

WARNING

W-501

Breathing dust containing silica could cause silicosis, a fatal lung disease. Breathing dust during abrasive blasting operations, post-blast cleaning operations, and/or servicing equipment within the abrasive blasting area may expose an individual to conditions that could cause asbestosis, lead poisoning and/or other serious or fatal diseases. Harmful dust containing toxic material from abrasives or surfaces being abrasive blasted can remain suspended in the air for long periods of time after abrasive blasting has ceased. A NIOSH-approved, well-maintained, respirator designed for the specific operation being performed must be used by anyone abrasive blasting, handling or using the abrasive, and anyone in the area of the dust. Failure to comply with the above warning could result in death or serious injury.

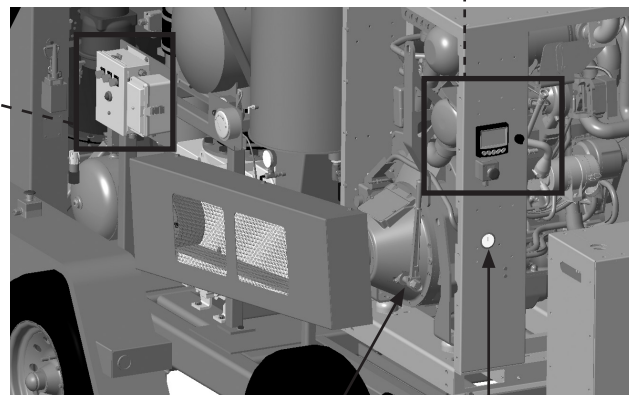
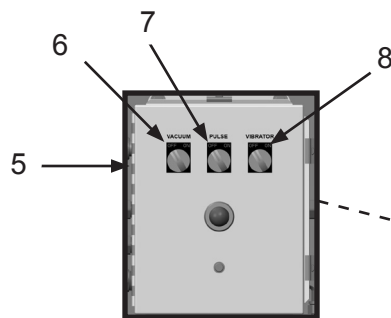

4 3

OPERATING INSTRUCTIONS

Adjust Vacuum Timer

WARNING

W-562

Always depressurize the entire system, disconnect all power sources and lockout/tagout all components before any maintenance or troubleshooting is attempted. Failure to comply with the above warning could cause electrical shock and inadvertent activation of equipment resulting in death or serious injury.

WARNING

This equipment is not intended for use in any area that might be considered a hazardous location, as described in the National Electric Code NFPA 70, Article 500. Use of this equipment in a hazardous location could cause an explosion or electrocution. Failure to comply with the above warning could result in death or serious injury.

WARNING

W-602

Stay clear of dump door while machine is in operation. Dump door activates automatically. Failure to comply with above warning could result in death or serious injury.

Note: Run times will need to be adjusted according to the bulk density of material being collected and length of hose.

Note: Dump Door (4) opens and closes automatically with timer control settings.

- 1) Turn Vacuum Selector Switch (1) in Vacuum Control Box to "OFF" position before adjusting timers.
- 2) Inside Vacuum Timer Control Box (2), the "T2" Knob (4) controls the time that vacuum runs and the "T1" Knob (3) controls the time that vacuum is off (dump time).
- 3) Turn knobs clockwise to increase time and counterclockwise to reduce time.

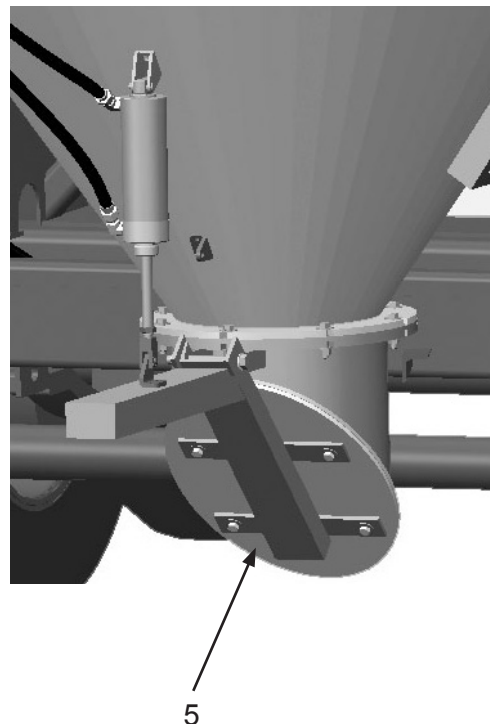
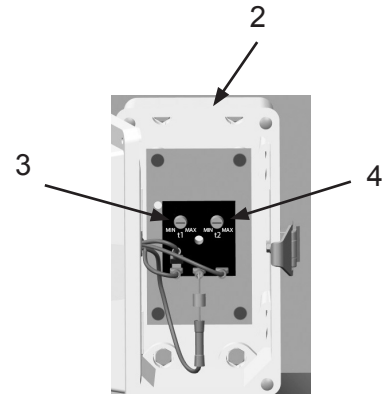
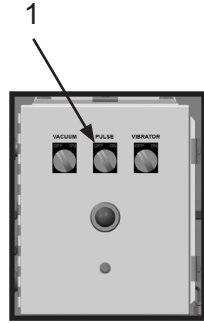

OPERATING INSTRUCTIONS

Pulser System Startup

WARNING

W-562

Always depressurize the entire system, disconnect all power sources and lockout/tagout all components before any maintenance or troubleshooting is attempted. Failure to comply with the above warning could cause electrical shock and inadvertent activation of equipment resulting in death or serious injury.

WARNING

This equipment is not intended for use in any area that might be considered a hazardous location, as described in the National Electric Code NFPA 70, Article 500. Use of this equipment in a hazardous location could cause an explosion or electrocution. Failure to comply with the above warning could result in death or serious injury.

WARNING

W-590

When performing service or maintenance on systems or devices requiring access from an elevated position, you must comply with all OSHA, local, City, State, Province, Country and jurisdiction regulations, ordinances and standards, as related to working in elevated work areas. Failure to comply with the above warning could result in death or serious injury.

Pulser System Startup Instructions:

The Pulser System is a cleaning system for the filter bags. This system blows a burst of air into a set of filters to dislodge dust from the filters into the hopper. To change time duration of pulse, see Adjust Pulse Separation.

- 1) Ensure Ball Valves (2) are closed.
- 2) To Pulse, turn "PULSE" Switch (1) on control box to "On".
- 3) While powered, the pulser system should be easily heard. The timer controller will be factory set.
- 4) Material will fall from the filters to the bottom of the hopper to dump during the dump cycle.

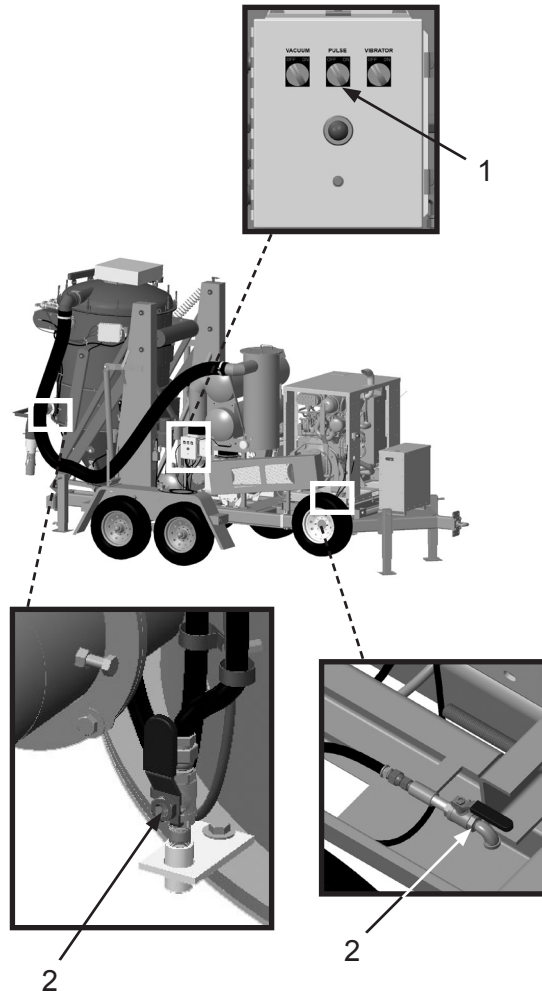

OPERATING INSTRUCTIONS

Reading Magnehelic Gauge

The Magnehelic Gauge provides a means to tell how clean the filter cartridges/bags are. It measures the static pressure and the resistance of air flow across the filters.

Magnehelic Gauge located on hopper

- New Filters will register approximately 1" water column (w.c.) on the gauge. Normal operating range for conditioned filters will show 20" – 30" (w.c.) on gauge.
- If Magnehelic Gauge is reading above the normal operating range, see Troubleshooting Section.

Magnehelic Gauge located near intake filter housing

- New Filters will register approximately 2" water column (w.c.) on the gauge. Normal operating range will register approximately 10" water column (w.c.) on the gauge.
- If Magnehelic Gauge reading climbs rapidly, stop operating the unit, perform shut-down procedure, and check pulser system and filter bags.
- If reading above 30" (w.c.), stop operating the unit immediately, perform shut-down procedure, check pulser system, and replace filter bags.

WARNING

W-577

Before using this equipment, read, understand and follow all instructions in the Operator's Manuals with this equipment. If the user and/or assistants cannot read or understand the warnings and instructions, the employer of the user and/or assistants must provide adequate and necessary training to ensure proper operation and compliance with all safety procedures pertaining to this equipment. If Operator's Manuals have been lost, visit www.allredi.com or call (281) 930-0808 for replacements. Failure to comply with the above warning could result in death or serious injury.

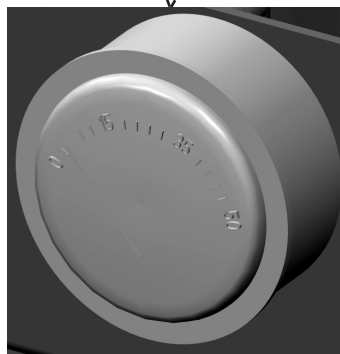
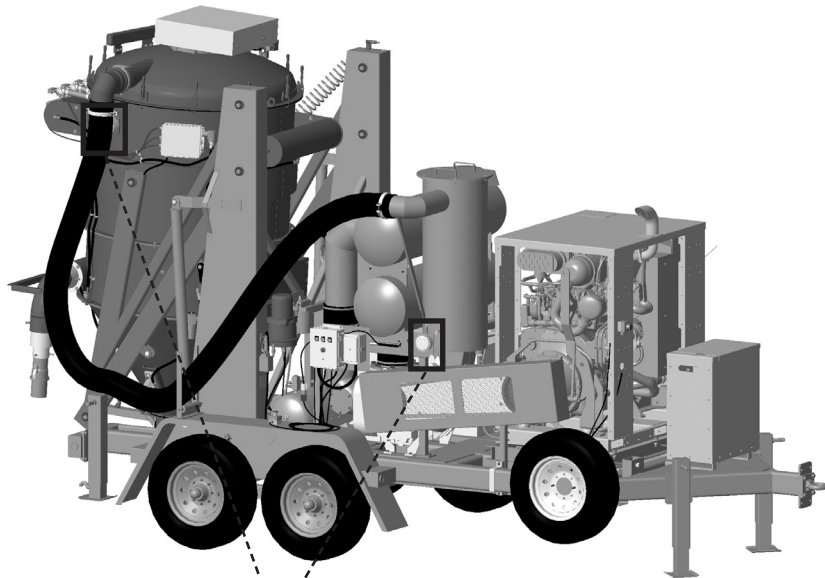

OPERATING INSTRUCTIONS

Lubricate Grease Points

Lubricate Vacmaster® 15T Tier 4 Diesel Abrasive Vacuums at points indicated. Points are indicated by Lubrication Point Grease Daily Decal (1).

⚠ WARNING

W-562

Always depressurize the entire system, disconnect all power sources and lockout/tagout all components before any maintenance or troubleshooting is attempted. Failure to comply with the above warning could cause electrical shock and inadvertent activation of equipment resulting in death or serious injury.

⚠ WARNING

W-587

Escaping fluid under pressure can penetrate skin and tissue causing injury. Stop pump and relieve pressure before attempting maintenance or repair. Ensure all fittings are properly tightened before restoring pressure. If injury should occur, immediately seek medical attention. Failure to comply with the above warning could result in death or serious injury.

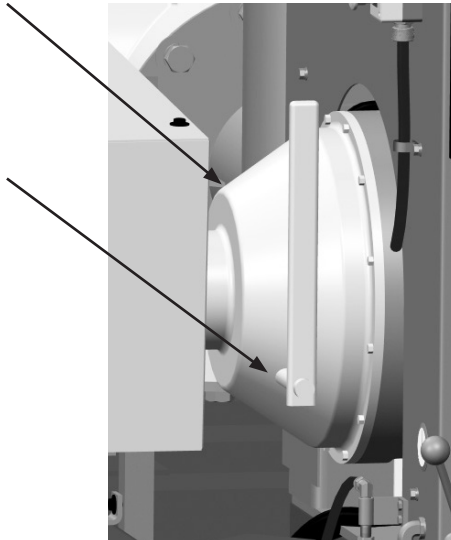

OPERATING INSTRUCTIONS

Lubricate Grease Points *(Cont.)*

Lubricate Vacmaster® 15T Tier 4 Diesel Abrasive Vacuums at points indicated. Points are indicated by Lubrication Point Grease Monthly Decal (1).

WARNING

W-562

Always depressurize the entire system, disconnect all power sources and lockout/tagout all components before any maintenance or troubleshooting is attempted. Failure to comply with the above warning could cause electrical shock and inadvertent activation of equipment resulting in death or serious injury.

WARNING

W-587

Escaping fluid under pressure can penetrate skin and tissue causing injury. Stop pump and relieve pressure before attempting maintenance or repair. Ensure all fittings are properly tightened before restoring pressure. If injury should occur, immediately seek medical attention. Failure to comply with the above warning could result in death or serious injury.

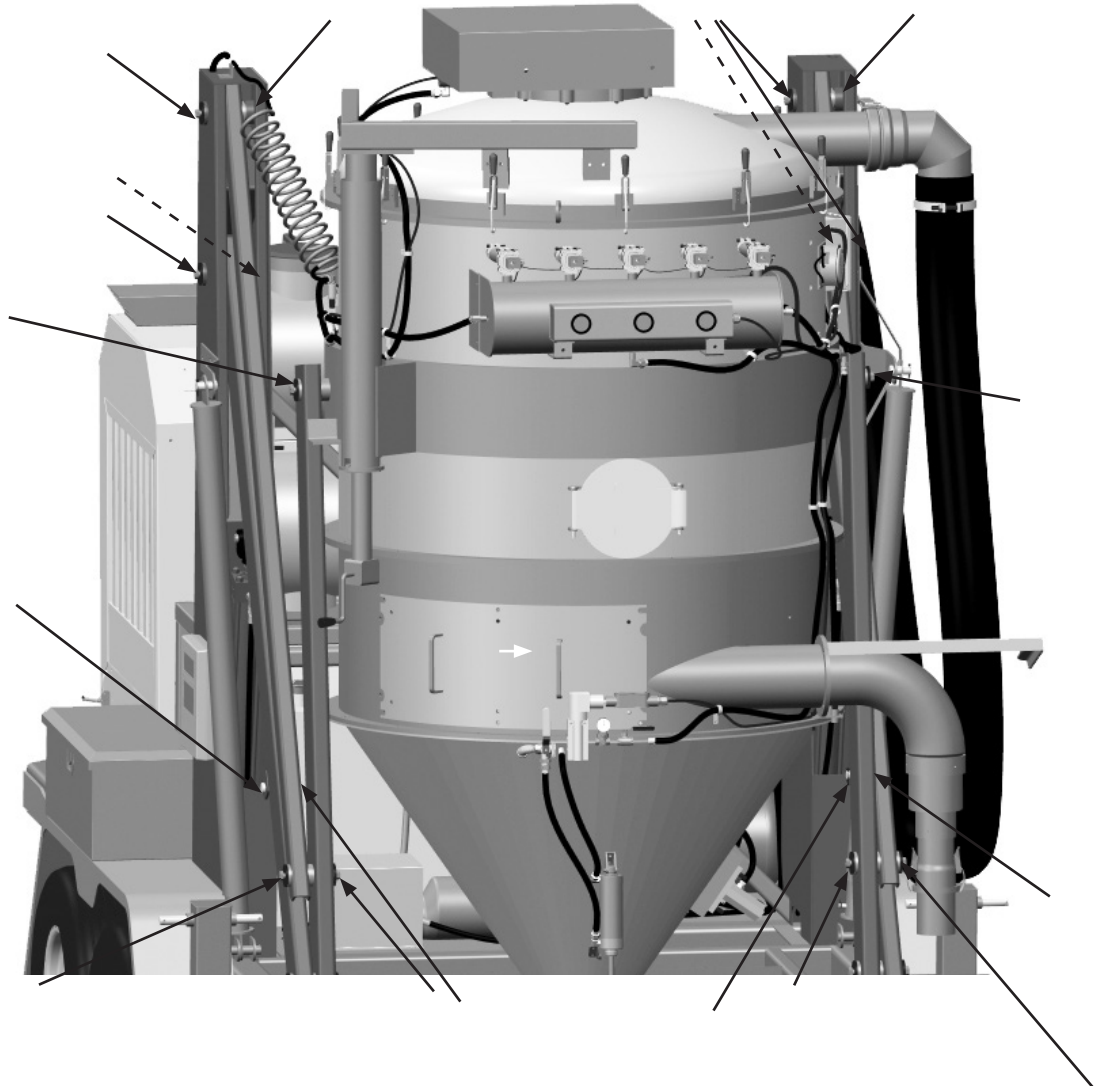

SPECIFICATIONS

Performance:	MAX 2367 CFM
Filter Cartridge Style:	Acrylic-Coated Filter Bags 37 Required
Filter Cleaning:	Pulse System, 25–30 second intervals. Pulse Duration: 200–350 millisecond
Vacuum	27" Hg
Ducting Connections:	6" I.D. Inlet with 4" adapter
Inspection Ports:	One 10" Viewable to Filters with access ports to hopper
Material Removal:	Automatic Direct Dump
Blower:	Rotary lobe, positive displacement with jet inlet
Engine:	Diesel, Tier 4 Final, 174 Horsepower
Fuel Capacity:	Capacity: 116 Gallons Type: Ultra Low Sulfur Diesel
Air Compressor:	On Board 13 CFM
Electrical System:	12-Volt DC
Engine Protection:	Engine Monitoring System with automatic shutdown
Fluid Specifications:	Hydraulic Oil: H46 or equivalent, 2 gallon capacity Diesel Fuel: Ultra Low Sulfur Diesel Grease/Lubricator: Shell Alvania Grease EP or equivalent Alcohol Evaporator: Alcohol 99 Isopropyl, 32 oz. capacity Vibrator Lubricator: 4 oz. pneumatic air tool oil DEF: BlueDEF Diesel Exhaust Fluid Blower Oil: ROOTS™ synthetic lubricating oil
Unit Dimensions:	Weight: 11,250 pounds (empty) Length: 19' 7" Width: 7' 10" Height: 11' 6" Raised Height: 19' Dump Clearance: 8'

MAINTENANCE

Adjust Tension of Blower Drive Belt

⚠ WARNING

W-562

Always depressurize the entire system, disconnect all power sources and lockout/tagout all components before any maintenance or troubleshooting is attempted. Failure to comply with the above warning could cause electrical shock and inadvertent activation of equipment resulting in death or serious injury.

⚠ WARNING

W-586

Moving parts can present an area where crushing, pinching, entanglement or amputation may occur. Do not place body parts or foreign objects in any area where there are moving parts. Failure to comply with the above warning could result in death or serious injury.

⚠ WARNING

W-590

When performing service or maintenance on systems or devices requiring access from an elevated position, you must comply with all OSHA, local, City, State, Province, Country and jurisdiction regulations, ordinances and standards, as related to working in elevated work areas. Failure to comply with the above warning could result in death or serious injury.

⚠ WARNING

W-583

Do not walk on, stand on, or climb on any surface other than the designated work platform. Doing so poses a slip and fall hazard. Failure to comply with the above warning could result in death or serious injury.

- 1) Depressurize system.
- 2) Disconnect battery cables from battery.
- 3) Remove three Bolts (1).
- 4) Remove Front Belt Cover (2).

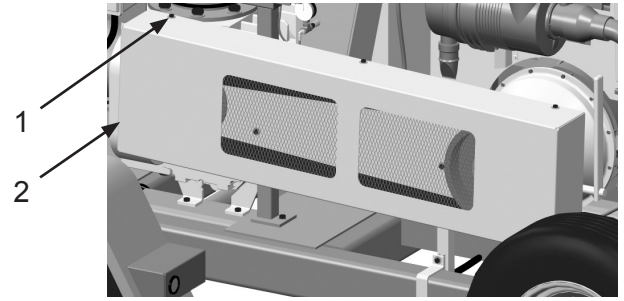

- 5) Inspect Belt (3) for damage. Replace as needed.
- 6) Check tension of Belt (3) by pushing downward on Belt and measure Distance (A) of travel. Belts should have a deflection distance of approximately $21/32$ inch; applied force of approximately 88–94 pounds.
- 7) To adjust tension of Belt, loosen Slide Bolts (4). Adjust threaded rod (5) until deflection distance is approximately $21/32$ inch; applied force of approximately 88–94 pounds. If distance cannot be attained, replace belt. Tighten Slide Bolts (4).
- 8) Install parts in reverse order using the following special instructions:
 - Use medium-strength thread-locker on all nuts and bolts.

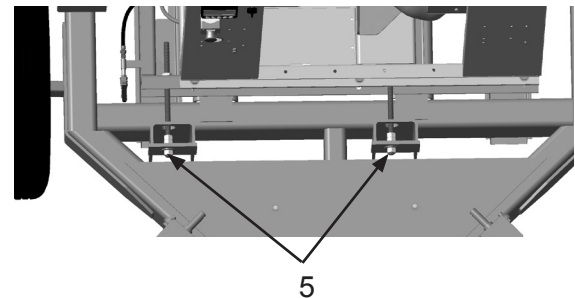
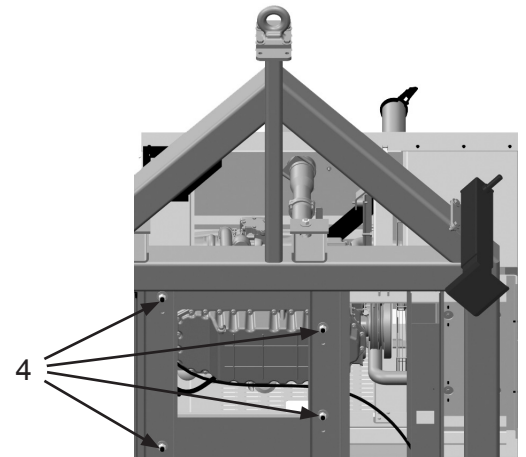
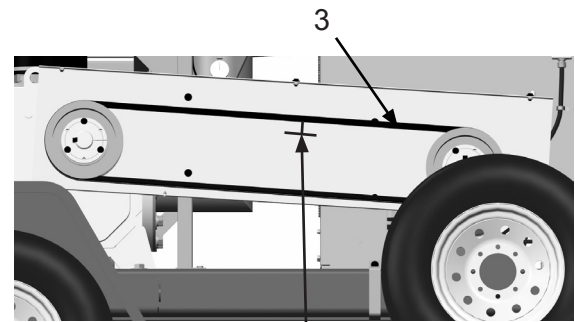

MAINTENANCE

Adjust Pulse Separation

WARNING

Always depressurize the entire system, disconnect all power sources and lockout/tagout all components before any maintenance or troubleshooting is attempted. Failure to comply with the above warning could cause electrical shock and inadvertent activation of equipment resulting in death or serious injury.

- 1) Depressurize system.
- 2) Disconnect battery cables from battery.
- 3) Open enclosure door of Timer Controller.
- 4) Locate Adjustment Knobs (1 and 2).

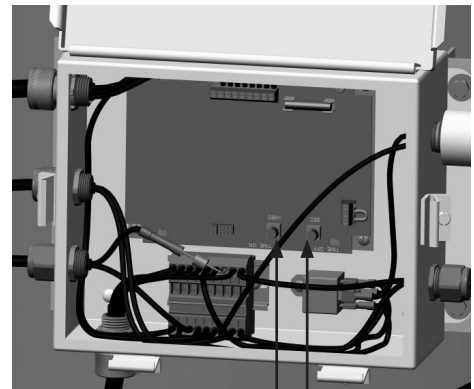

- 5) Set the Pulse Separation, the elapsed time between pulses, by rotating Knob (3). The recommended elapsed time between pulses is 25 seconds. Depending on conditions, the elapsed time may need to be changed. Elapsed time between pulses should be between 20–30 seconds.



- 6) Set Pulse Duration, the elapsed time of compressed air entering the filters, by rotating Knob (4). The recommended elapsed time of compressed air entering the filters is 200 milliseconds (mSEC). Depending on conditions, the elapsed time of air entering the filters should be between 200–350 milliseconds.
- 7) Close enclosure door of Timer Controller.



MAINTENANCE

Remove & Install Blower Drive Belt Assembly

⚠ WARNING

W-562

Always depressurize the entire system, disconnect all power sources and lockout/tagout all components before any maintenance or troubleshooting is attempted. Failure to comply with the above warning could cause electrical shock and inadvertent activation of equipment resulting in death or serious injury.

⚠ WARNING

W-586

Moving parts can present an area where crushing, pinching, entanglement or amputation may occur. Do not place body parts or foreign objects in any area where there are moving parts. Failure to comply with the above warning could result in death or serious injury.

⚠ WARNING

W-590

When performing service or maintenance on systems or devices requiring access from an elevated position, you must comply with all OSHA, local, City, State, Province, Country and jurisdiction regulations, ordinances and standards, as related to working in elevated work areas. Failure to comply with the above warning could result in death or serious injury.

- 1) Depressurize system.
- 2) Disconnect battery cables from battery.
- 3) Remove three Bolts (1).
- 4) Remove Front Belt Cover (2).

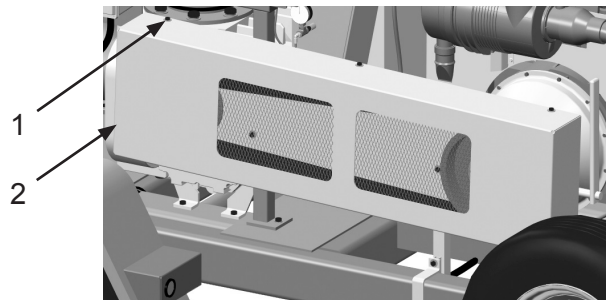

- 5) Loosen Slide Bolts (4).
- 6) Remove tension of belt by adjusting Threaded Rods (5) until belt is loose enough to remove.
- 7) Remove Belt (3).

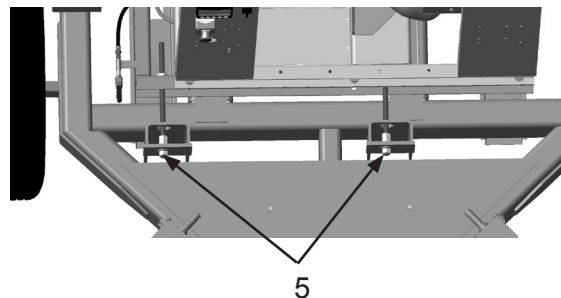
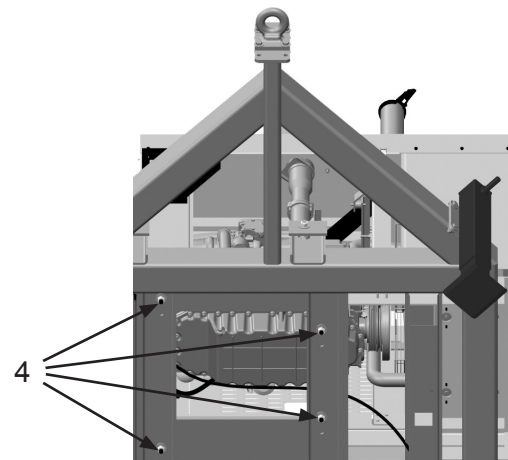
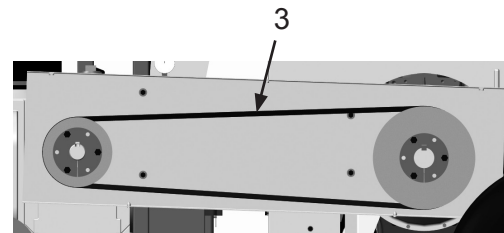

MAINTENANCE

Remove & Install Blower Drive Belt Assembly (Cont.)

WARNING

W-562

Always depressurize the entire system, disconnect all power sources and lockout/tagout all components before any maintenance or troubleshooting is attempted. Failure to comply with the above warning could cause electrical shock and inadvertent activation of equipment resulting in death or serious injury.

WARNING

W-586

Moving parts can present an area where crushing, pinching, entanglement or amputation may occur. Do not place body parts or foreign objects in any area where there are moving parts. Failure to comply with the above warning could result in death or serious injury.

NOTICE

N-530

Label all hoses and connections to aid installation.

- 8) Remove six Bolts and Lock Washers (6) and Bushings (7).
- 9) Remove Sheaves (8) and Keys (9) from shaft.
- 10) Remove four Bolts, Lock Washers and eight Washers (10) from Belt Guard Back (11).
- 11) Remove Belt Guard Back (11).

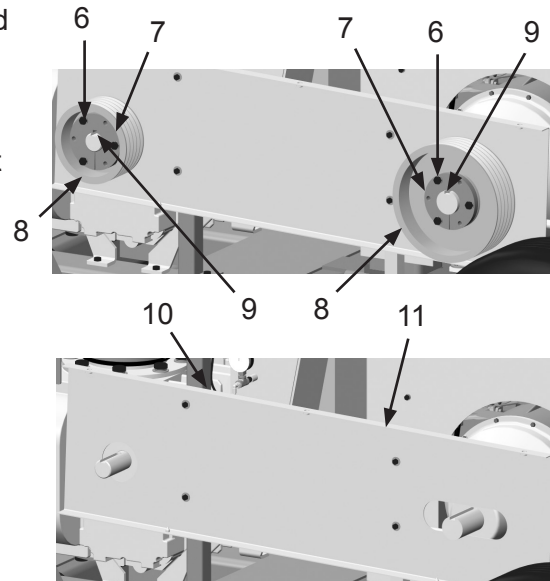

- 12) Remove two Bolts, Lock Washers and four Washers (12) from two piece Belt Guard Bracket (13).
- 13) Remove two piece Belt Guard Bracket (13).
- 14) Install parts in reverse order using the following special instructions:
 - Use medium-strength thread-locker on all nuts and bolts.
 - Adjust blower drive belt tension. See Adjust Tension of Blower Drive Belt.

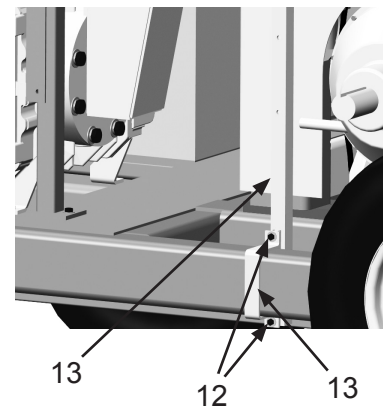

MAINTENANCE

Remove & Install Filter Bags

⚠ WARNING

W-562

Always depressurize the entire system, disconnect all power sources and lockout/tagout all components before any maintenance or troubleshooting is attempted. Failure to comply with the above warning could cause electrical shock and inadvertent activation of equipment resulting in death or serious injury.

⚠ WARNING

W-501

Breathing dust containing silica could cause silicosis, a fatal lung disease. Breathing dust during abrasive blasting operations, post-blast cleaning operations, and/or servicing equipment within the abrasive blasting area may expose an individual to conditions that could cause asbestosis, lead poisoning and/or other serious or fatal diseases. Harmful dust containing toxic material from abrasives or surfaces being abrasive blasted can remain suspended in the air for long periods of time after abrasive blasting has ceased. A NIOSH-approved, well-maintained, respirator designed for the specific operation being performed must be used by anyone abrasive blasting, handling or using the abrasive, and anyone in the area of the dust. Failure to comply with the above warning could result in death or serious injury.

- 1) Depressurize system.
- 2) Loosen Clamp (1) and remove Hose Tube (5) and Vacuum Hose (4).
- 3) Lower Lid Clamps (2) to free Lid (3).

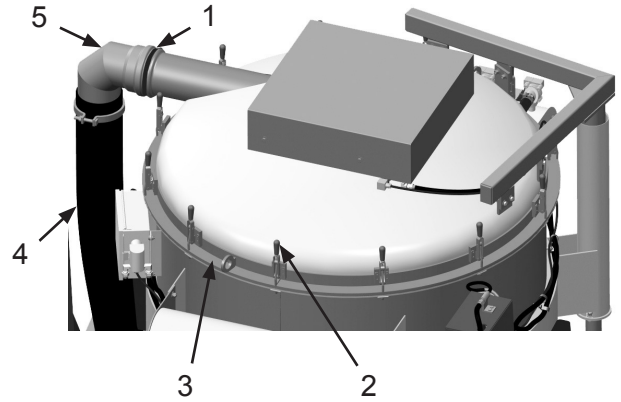

- 4) Turn Crank (7) to raise Lid (9).
- 5) Rotate lid on Shaft (6) counterclockwise until clear of Hopper (8).

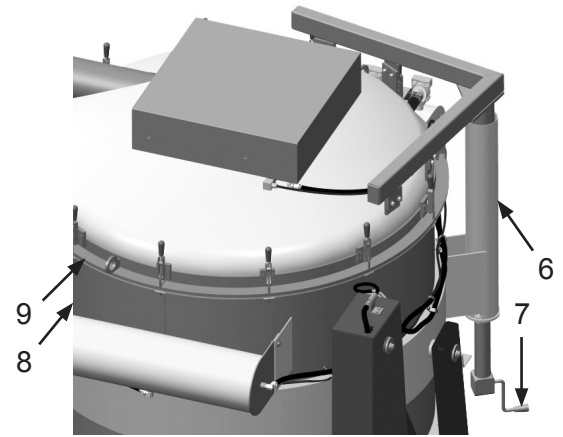

- 6) Remove four Bolts, Washers and Nuts (10). Remove Frame (11).
- 7) Remove Air Hose with Clamps (12) from Pulser System Blowpipes (13).
- 8) Remove Pulser System Blowpipes (13).
- 9) Remove Filter Bags (14).
- 10) Install parts in reverse order using the following special instructions:
 - Use medium-strength thread-locker on all nuts and bolts.

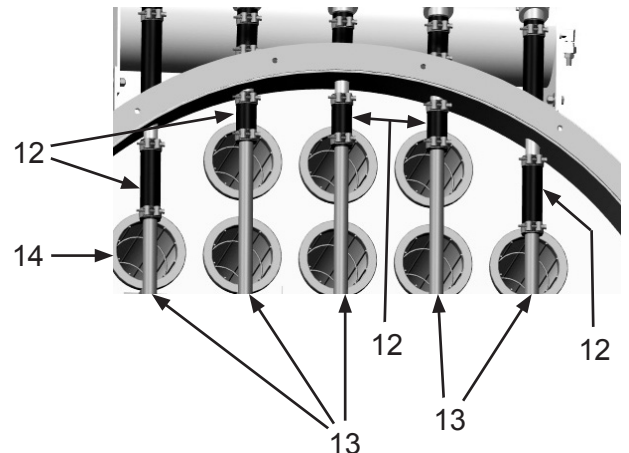
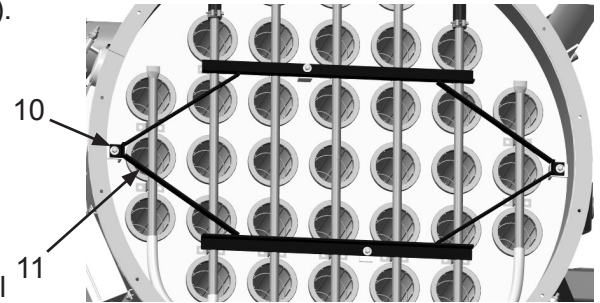

MAINTENANCE

Remove & Install Filter Cartridge

⚠ WARNING

W-562

Always depressurize the entire system, disconnect all power sources and lockout/tagout all components before any maintenance or troubleshooting is attempted. Failure to comply with the above warning could cause electrical shock and inadvertent activation of equipment resulting in death or serious injury.

⚠ WARNING

W-501

Breathing dust containing silica could cause silicosis, a fatal lung disease. Breathing dust during abrasive blasting operations, post-blast cleaning operations, and/or servicing equipment within the abrasive blasting area may expose an individual to conditions that could cause asbestosis, lead poisoning and/or other serious or fatal diseases. Harmful dust containing toxic material from abrasives or surfaces being abrasive blasted can remain suspended in the air for long periods of time after abrasive blasting has ceased. A NIOSH-approved, well-maintained, respirator designed for the specific operation being performed must be used by anyone abrasive blasting, handling or using the abrasive, and anyone in the area of the dust. Failure to comply with the above warning could result in death or serious injury.

- 1) Depressurize system.
- 2) Remove six Bolts, Lock Washers and Nuts (1).
- 3) Remove Filter Cap and Housing Gasket (2).

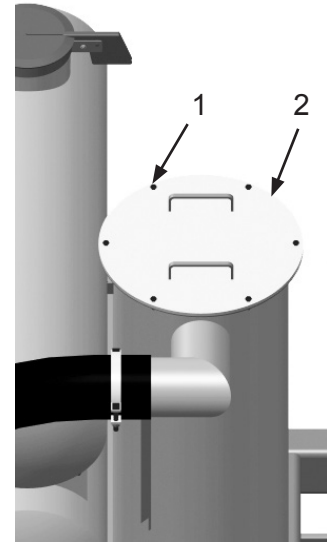

- 4) Remove Nut, Washer and Rubber Washer (3).
- 5) Remove Filter (4).
- 6) Install parts in reverse order using the following special instructions:
 - Use medium-strength thread-locker on all nuts and bolts.

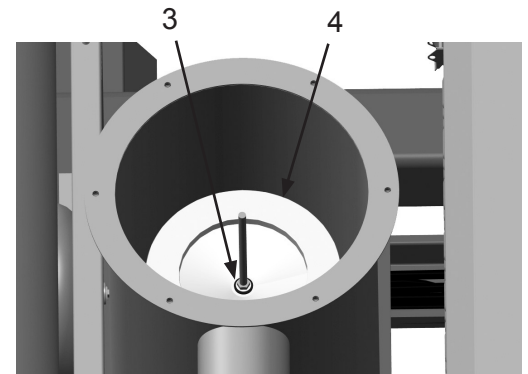

MAINTENANCE

Check Lubricator Oil Level

⚠ WARNING

W-562

Always depressurize the entire system, disconnect all power sources and lockout/tagout all components before any maintenance or troubleshooting is attempted. Failure to comply with the above warning could cause electrical shock and inadvertent activation of equipment resulting in death or serious injury.

⚠ WARNING

W-587

Escaping fluid under pressure can penetrate skin and tissue causing injury. Stop pump and relieve pressure before attempting maintenance or repair. Ensure all fittings are properly tightened before restoring pressure. If injury should occur, immediately seek medical attention. Failure to comply with the above warning could result in death or serious injury.

⚠ WARNING

W-589

Exposure to diesel fuel, lubricant grease and oil, hydraulic oil, or engine coolant can cause personal injury. Do not allow these products to remain in contact with the skin or eyes. Ingestion of these products or inhalation of fumes from these products can cause dizziness, nausea, vomiting, or poisoning. If exposure to any of these products occurs, or if any of these products are ingested or if fumes are inhaled, please consult the product's SDS for proper first aid or medical procedures. Failure to comply with the above warning could result in death or serious injury.

- 1) Check oil level in Sight Glass (3).
- 2) To add oil, close Ball Valve (1).
- 3) Pull down Lock Tab (2) and twist container (4) counterclockwise to release.
- 4) Add oil and install parts in reverse order.
- 5) Set oil drip rate if needed by turning the Site Dome Adjustment Screw (5).

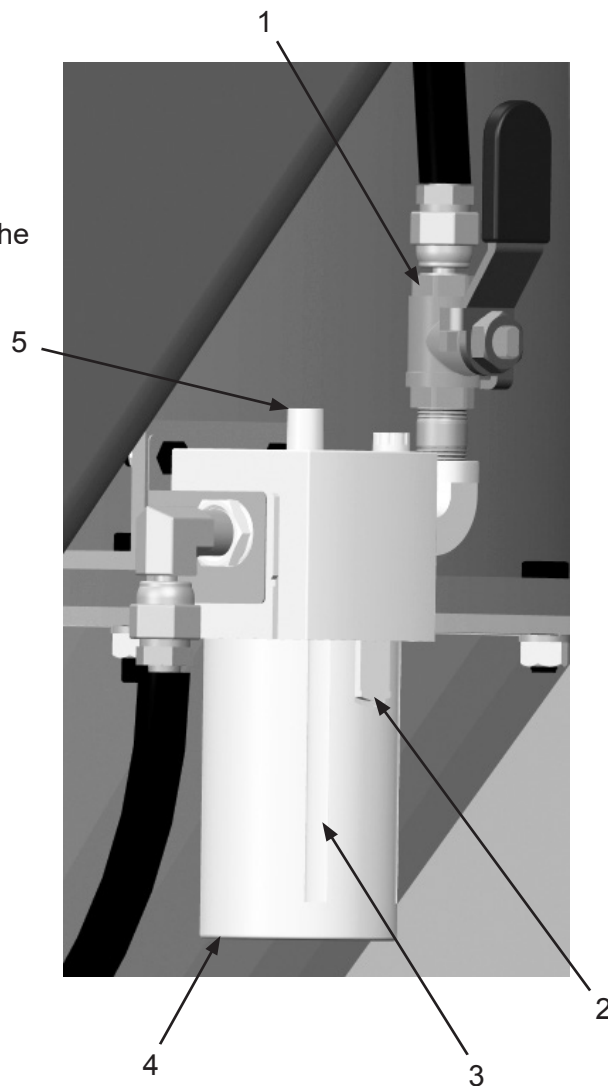

MAINTENANCE

Remove & Install Hopper Access Door Wear Plate

WARNING

W-562

Always depressurize the entire system, disconnect all power sources and lockout/tagout all components before any maintenance or troubleshooting is attempted. Failure to comply with the above warning could cause electrical shock and inadvertent activation of equipment resulting in death or serious injury.

- 1) Depressurize system.
- 2) Close Ball Valve (1)
- 3) Remove six Nuts, Lock Washers and Washers (2).
- 4) Remove Hopper Access Door (3).
- 5) Remove six Nuts, Lock Washers and Washers (5).
- 6) Remove Hopper Access Door Wear Plate (4).
- 7) Install parts in reverse order using the following special instructions:
 - Use medium-strength thread-locker on all nuts and bolts.

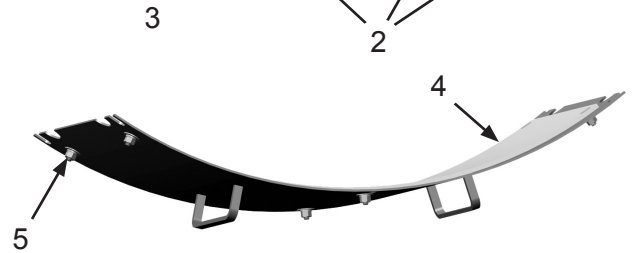
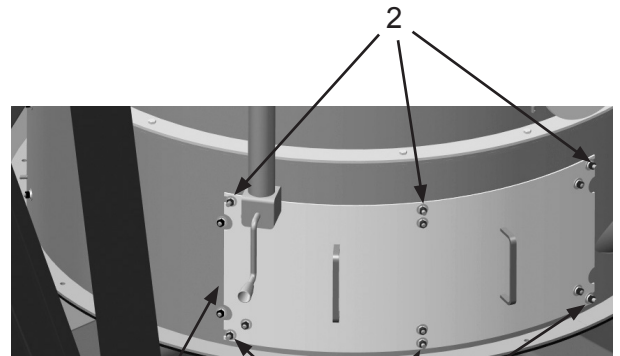

MAINTENANCE

Hazard Identification Decals

⚠ DANGER



- Do not raise hopper unless vacuum is on a level surface and jack stands are down and secured using a proper device
- Do not leave hopper in raised position without support strut in place and secured using a proper device.
- Do not move vacuum while hopper is in raised position.

Failure to comply with above warning could result in death or serious injury.

⚠ WARNING



Do not walk on, stand on, or climb on any surface. Doing so poses a slip and fall hazard. Failure to comply with above warning could result in death or serious injury.

Start-Up Operation:

Pre-Start-Up Checks

- Check Engine Oil, Fuel, Coolant, Blower oil, and Hydraulic oil levels.
- Grease Clutch Assembly.
- Grease Lift Arm Cylinders.
- Ensure Emergency Stops are reset.

Pulser System Start-Up

- Ensure air system blow down valves are shut, (1) located near engine, (1) located on hopper.
- To Pulse, turn Pulse Switch on control box to "On".
- While powered the pulser system should be easily heard. The timer controller will be factory set.
- Material will fall from the filters to the bottom of the hopper to dump during the dump cycle.

Blower Engagement

- Ensure that personnel are away from blower exhaust and inlet openings.
- Let the engine warm up for about five minutes.
- Slowly engage clutch until fully engaged and handle is in its locked position.
- Rapid engagement may cause belts to slip from pulleys and damage to clutch.

⚠ WARNING



STATIC DISCHARGE

Ground machine to a suitable ground before operation. Failure to comply with above warning could result in death or serious injury.

⚠ CAUTION



LOUD NOISE HAZARD

Hearing protection must be worn when operating this equipment. Failure to comply with above warning could result in personal injury.

ⓘ NOTICE

Do Not Allow DEF Tank To Run Below 30%

⚠ CAUTION

DIESEL EXHAUST FLUID (DEF) ONLY

⚠ WARNING



Before using this equipment, read, understand and follow all instructions in the Operator's Manuals with this equipment. If the user and/or assistants cannot read or understand the warnings and instructions, the employer of the user and/or assistants must provide adequate and necessary training to ensure proper operation and compliance with all safety procedures pertaining to this equipment. If Operator's Manuals have been lost, visit www.marco.us or call (603) 324-2519 for replacements. Failure to comply with above warning could result in death or serious injury.

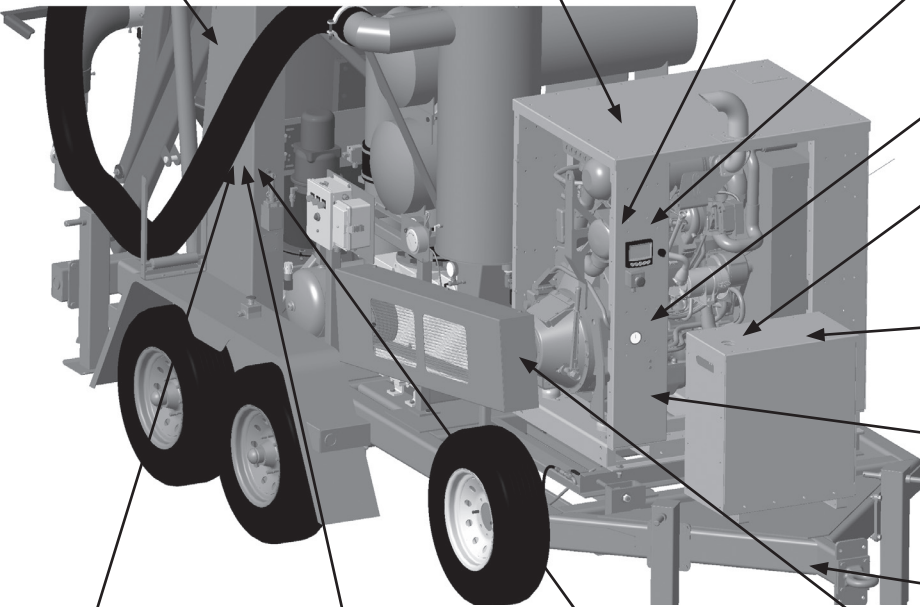

⚠ WARNING



POWER LINES

Do not raise hopper under electric wires or any obstruction. Failure to comply with above warning could result in death or serious injury.

⚠ CAUTION



SECURE HOSE

Vacuum hose may suddenly move causing you to lose balance. Failure to comply with the above warning could result in minor or moderate injury.

⚠ WARNING



HIGH WINDS

Do not use in raised position with winds greater than 28 MPH. Failure to comply with above warning could result in death or serious injury.

⚠ WARNING



Rotating or moving parts can pinch, crush, or entangle when in motion.

Follow proper lockout/tagout procedures before servicing.

⚠ WARNING

DO NOT EXCEED 55 MPH.

DO NOT TOW VACUUM WITH HOPPER IN RAISED POSITION.

Exceeding speed limit could cause damage to components and the unit to become unstable causing it to tip over or cause the tow vehicle to become unstable. Failure to comply with the above warning could result in death or serious injury.

SPEED LIMIT

55

MAINTENANCE

Hazard Identification Decals (Cont.)

ALLREDI™
 For Service or Parts Call:
 800.252.7848 | WWW.ALLREDI.COM

**DIESEL VACUUM START-UP/
 SHUT-DOWN INSTRUCTIONS**

VACUUM UNIT START-UP:

1. Start Engine.
2. Allow compressed air system to build pressure to 100 psi before vacuum use.
3. Before lifting hopper, lower jacks. Raise hopper and install locking pins.
4. Plug in E-stop pendant near vacuum controls. Pull red knob out.
5. Set desired time on vacuum timer for vacuum cycle.
6. Ensure engine is at low idle. Engage engine clutch.
7. Move Vacuum switch to "ON" position.
8. Move Pulse switch to "ON" position.
9. Move Vibrator switch to "ON" position.
10. Start Vacuuming.

VACUUM UNIT SHUT DOWN:

1. Allow material to clear vacuum hose.
2. Ensure engine is at low idle. Disengage clutch.
3. Move vacuum switch to "OFF" position.
4. Allow pulse system to operate for 5 minutes.
5. Move vibrator switch to "OFF" position
6. Turn off engine.
7. Drain air tanks.

VACUUM UNIT TRANSPORTATION:

1. Ensure hopper is empty and discharge door is secured in the closed position.
2. Shut down unit.
3. Remove hopper safety supports from lift arms; secure to trailer.
4. Push "LOWER" button to lower hopper from raised position.
5. Disconnect vacuum hose from inlet elbow.
6. Raise rear trailer support jacks before transport.
7. Tow unit with proper tow vehicle with electric brake controller. Do not exceed 55 mph speed limit.

1094536_Rev A_Diesel Vacuums

WARNING



DO NOT OPEN DOOR WHEN MACHINE IS OPERATING.
 Failure to comply with above warning could result in death or serious injury.

DANGER



DO NOT VACUUM FLAMMABLE MATERIAL.
-EXPLOSION POSSIBLE-
 Failure to comply with above warning could result in death or serious injury.

WARNING



CONFINED SPACE
 AUTHORIZED PERSONNEL ONLY
 Special precautions required before entering. Entry limited to trained personnel only. Compliance with all applicable regulations is required before entry is permitted.

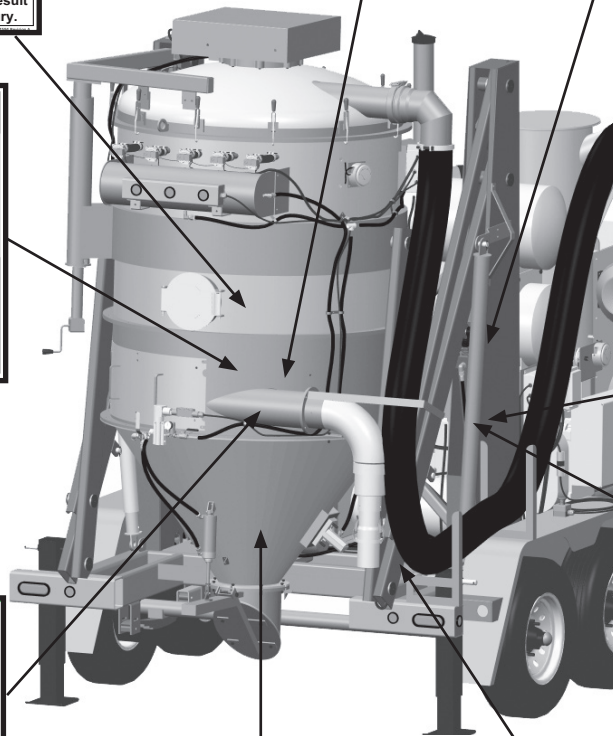

WARNING

POWERFUL SUCTION!
 Keep hands, all parts of body, hair and clothing away from hose end.
 Failure to comply with above warning could result in death or serious injury.

WARNING

STAY CLEAR
OPERATES AUTOMATICALLY
 Failure to comply with above warning could result in death or serious injury.

WARNING



Rotating or moving parts can pinch, crush, or entangle when in motion. Follow proper lockout/tagout procedures before servicing.

DANGER



Do not leave hopper in raised position without support strut in place and secured using a proper device.
 Failure to comply with above warning could result in death or serious injury.

1094579 Revision A

DANGER



Do not leave hopper in raised position without support strut in place and secured using a proper device.
 Failure to comply with above warning could result in death or serious injury.

1094579 Revision A

MAINTENANCE

Hazard Identification Decals (Cont.)

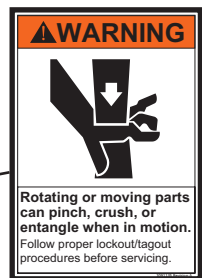
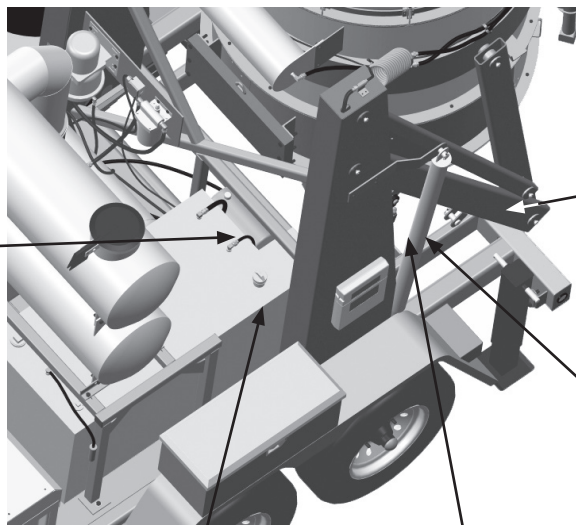

MAINTENANCE

Hazard Identification Decals (Cont.)

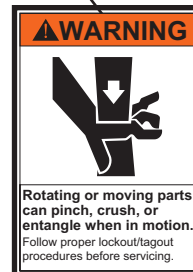
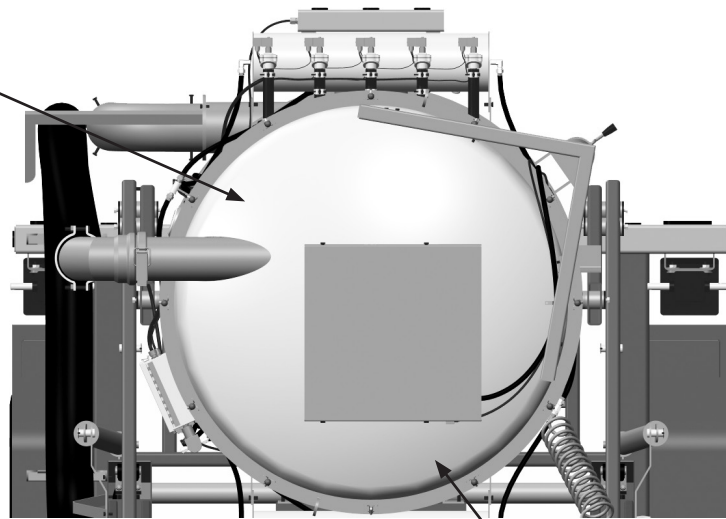

TROUBLESHOOTING

If the Vacmaster® 15T Tier 4 Diesel Abrasive Vacuum does not function properly, check the following:

WARNING

W-562

Always depressurize the entire system, disconnect all power sources and lockout/tagout all components before any maintenance or troubleshooting is attempted. Failure to comply with the above warning could cause electrical shock and inadvertent activation of equipment resulting in death or serious injury.

SYMPTOM (Cause)

ACTION

Diesel Engine will not start or runs poorly

(Damaged components, insufficient connections, fuel supply)

See original equipment Operator's Manual for service.

Drive Belt slips or vibrates

(Loose connections, worn parts)

Inspect Blower Drive Belt for damage. Replace as needed.

Inspect alignment.

Adjust Blower Drive Belt Tension. See Adjust Blower Drive Belt Tension.

Magnehelic Gauge reading greater than normal operating range

(Hopper Filter Bags)

A reading greater than 40" (w.c.) on Magnehelic Gauge indicates clogged filters. Decrease engine RPM to idle speed and disengage clutch while allowing engine to run. Pulsers will clean down the filters. Once gauge reads back into the normal operation range of 20" – 30" (w.c), re-engage clutch and increase RPM to operating speed.

If Magnehelic Gauge is reading above 30" (w.c.), perform After Use procedure. Inspect Pulser System and Filters. Replace filter bags, if needed.

If Magnehelic Gauge is reading above 40" (w.c.), shut down unit immediately. Replace filter bags.

TROUBLESHOOTING

WARNING

W-562

Always depressurize the entire system, disconnect all power sources and lockout/tagout all components before any maintenance or troubleshooting is attempted. Failure to comply with the above warning could cause electrical shock and inadvertent activation of equipment resulting in death or serious injury.

WARNING

W-586

Moving parts can present an area where crushing, pinching, entanglement or amputation may occur. Do not place body parts or foreign objects in any area where there are moving parts. Failure to comply with the above warning could result in death or serious injury.

SYMPTOM (Cause)

Filter Pulsar System pressurizes but does not pulse

(No power to control box, blown fuse in control box or timer board, disconnected wires, timer board, solenoid, diaphragm valve)

ACTION

Inspect all power connections. Repair or replace faulty connections.

Turn main power switch "OFF". Replace fuse if required.

Inspect all solenoids and listen for audible sound as it engages to pulse. Replace solenoid.

Inspect diaphragm valve breather vent for obstruction.

Pulsar System leaks

(Loose or missing hoses or connections, loose or missing urethane tubing, damaged diaphragm valves)

Check hose and hose connections between diaphragm valves and hopper wall.

Check all tubing for secure connections and fittings. If fittings do not fit tightly in hose, cut a small section from the end of the hose and re-insert fitting in tube.

Inspect diaphragm valve for damage or debris. Repair or replace diaphragm valve.

ADDITIONAL TECHNICAL DATA

The associations listed below offer information, materials and videos pertaining to abrasive blasting and safe operating practices.

- **American Society for Testing and Materials (ASTM)**

100 Barr Harbor Drive
West Conshohocken,
PA 19428-2959

Phone: (610) 832-9585
FAX: (610) 832-9555
www.astm.org

- **Occupational Safety & Health Administration (OSHA)**

United States
Department of Labor
200 Constitution Avenue
Washington, DC 20210

Phone: (800) 321-OSHA
(800) 321-6742
www.osha.gov

- **The National Board of Boiler & Pressure Vessel Inspectors**

1055 Crupper Avenue
Columbus, Ohio 4322

Phone: (614) 888-8320
FAX: (614) 888-0750
www.nationalboard.org

- **The Association for Materials Protection and Performance (AMPP)**

800 Trumbull Drive
Pittsburgh, PA 15205

Phone: (277) 281-7772

15835 Park Ten Place
Houston, TX 77084

Phone: (800) 797-6223

4501 Mission Bay Drive
Suite 2G

San Diego, CA 92109
Phone: (858) 768-0828
www.ampp.org

- **American National Standards Institute (ANSI)**

1899 L Street, NW, 11th Floor
Washington, DC 20036

Phone: (202) 293-8020
FAX: (202) 293-9287
www.ansi.org

LIMITED WARRANTY

Seller warrants to the original purchaser that the Product covered by this Limited Warranty will remain free from defects in workmanship or material under normal commercial use and service for a period of one year from the date of shipment to the original Purchaser. This Warranty shall not apply to defects arising, in whole or in part, from any accident, negligence, alteration, misuse or abuse of the Product, operation of the Product which is not in accordance with applicable instructions or manuals or under conditions more severe than, or otherwise exceeding, those set forth in the written specifications for the Product, nor shall this Warranty extend to repairs or alterations of the Product and/or any maintenance part by persons other than Seller or Seller's authorized representatives. This warranty does not apply to accessory items. Further, this Warranty does not apply to damage or wear to the surface finish or appearance of the Product or normal wear and tear to the Product. This Warranty is limited to a purchaser who purchases the Product either directly from the Seller or from one of Seller's "Authorized Distributors". An Authorized Distributor is a Seller approved distributor that purchases the Product directly from the Seller for the sole purpose of re-selling the Product at retail, without any use or modifications whatsoever, to an end-purchaser. This warranty is specifically non-assignable and non-transferable.

DISCLAIMER OF WARRANTY

The foregoing Limited Warranty is exclusive and is in lieu of all other warranties, whether oral or written and whether express, implied, or statutory. SELLER HEREBY DISCLAIMS ALL OTHER WARRANTIES, INCLUDING BUT NOT LIMITED TO THE WARRANTIES OF MERCHANTABILITY AND/OR FITNESS FOR A PARTICULAR PURPOSE AND ALL SUCH OTHER WARRANTIES ARE HEREBY EXCLUDED AND ARE INAPPLICABLE TO THE PRODUCT. Seller makes no warranties or representations of any kind concerning respirators, or equipment made by other manufacturers. Seller's agents and representatives are not authorized to offer any further warranties.

EXCLUSIVE REMEDY FOR WARRANTY CLAIMS

THE SOLE AND EXCLUSIVE REMEDY UNDER THE FOREGOING LIMITED WARRANTY, AND TO THE EXTENT PERMITTED BY LAW, ANY WARRANTY OR CONDITION IMPLIED BY LAW, COVERING THIS PRODUCT SHALL BE, AT THE SELLER'S OPTION, THE REPAIR OR REPLACEMENT, FREE OF CHARGE, F.O.B. POINT OF MANUFACTURE, OF ANY DEFECTIVE PART OR PARTS OF THE PRODUCT THAT WERE MANUFACTURED BY SELLER, AND WHICH ARE RETURNED TO SELLER AT SELLER'S PRINCIPAL PLACE OF BUSINESS, POSTAGE PREPAID BY THE PURCHASER. THIS SOLE AND EXCLUSIVE REMEDY IS CONDITIONED UPON PURCHASER'S PROMPT WRITTEN NOTICE TO SELLER AT SELLER'S PLACE OF BUSINESS THAT A DEFECT HAS BEEN DISCOVERED, TOGETHER WITH A REASONABLY DETAILED DESCRIPTION OF THE DEFECT IN THE PRODUCT, PROOF OF PURCHASE OF THE PRODUCT, AND THE MODEL AND IDENTIFICATION NUMBER OF THE PRODUCT WITHIN THIRTY (30) DAYS AFTER DISCOVERY OF THE DEFECT, OTHERWISE SUCH CLAIMS SHALL BE DEEMED WAIVED. NO ALLOWANCE WILL BE GRANTED FOR ANY REPAIRS OR ALTERATIONS MADE BY PURCHASER OR OTHERS WITHOUT SELLER'S PRIOR WRITTEN CONSENT. IF SUCH NOTICE IS TIMELY GIVEN, SELLER WILL HAVE THE OPTION TO EITHER MODIFY THE PRODUCT OR COMPONENT PART THEREOF TO CORRECT THE DEFECT, REPLACE THE PRODUCT OR PART WITH COMPLYING PRODUCTS OR PARTS, OR REFUND THE AMOUNT PAID FOR THE DEFECTIVE PRODUCT, ANY ONE OF WHICH WILL CONSTITUTE THE SOLE LIABILITY OF SELLER AND FULL SETTLEMENT OF ALL CLAIMS. IN NO EVENT SHALL SELLER BE LIABLE FOR ANY OBLIGATION GREATER THAN THE ORIGINAL PURCHASE PRICE OF THE PRODUCT UNDER THIS WARRANTY. PURCHASER SHALL AFFORD SELLER PROMPT AND REASONABLE OPPORTUNITY TO INSPECT THE PRODUCT FOR WHICH A CLAIM IS MADE. THE SOLE PURPOSE OF THE FOREGOING STIPULATED EXCLUSIVE REMEDY SHALL BE TO REPAIR OR REPLACE DEFECTIVE PRODUCTS OR COMPONENTS THEREOF, OR TO REFUND PURCHASER THE PURCHASE PRICE THEREOF. THIS STIPULATED EXCLUSIVE REMEDY SHALL NOT BE DEEMED TO HAVE FAILED OF ITS ESSENTIAL PURPOSE SO LONG AS SELLER IS WILLING AND ABLE TO REPAIR OR REPLACE THE DEFECTIVE PARTS OR REFUND THE PURCHASE PRICE IN ACCORDANCE WITH THE TERMS HEREOF. PRODUCTS THAT HAVE BEEN REPAIRED OR REPLACED UNDER THIS WARRANTY DO NOT RECEIVE A NEW WARRANTY AND ARE ONLY COVERED BY THE REMAINING PORTION OF THE ORIGINAL WARRANTY.

LIMITATION OF REMEDIES

The foregoing stipulated exclusive remedy is in lieu of all other remedies for breach of contract, warranty, and/or tort or otherwise. Seller shall not be liable, either directly or indirectly, for any consequential, incidental or special losses or damages of Purchaser, including but not limited to the Purchaser's expenses for downtime or for making up downtime, damages for which the Purchaser may be liable to other persons and/or entities, damages to property, and injury to or death of any persons and/or any claims for incidental or consequential damages, including but not limited to loss of profits, regardless of whether Seller has been informed of the possibility of such damages. Seller neither assumes, nor authorizes any person to assume for it, any other liability in connection with the sale or use of any Products covered by the foregoing Warranty and Disclaimers, and there are no oral agreements relating to remedies which are collateral to or which affect this limitation.



ALLREDI THERE

Serving these industries: Bridge, Pipeline, Tank & Tower, Concrete Services, Rail, Shipyard & Marine, Pools & Fountains and Foundry

UNITED STATES

Pasadena, TX (Headquarters)
281.930.0808

Beaumont, TX
409.722.1284

Bristol, PA
215.826.8080

Corpus Christi, TX
361.887.2038

Davenport, IA
563.324.2519

Deer Park, TX
(Service & Rental Location)
281.930.0905

Duluth, GA
770.938.7263

Gonzales, LA
225.647.7575

Harvey, LA
504.367.8090

Houma, LA
985.580.4273

Lafayette, LA
337.267.1440

Theodore, AL
251.338.7525

CANADA

Calgary, Alberta
403.279.1924

Coquitlam, BC
604.464.6979

Edmonton, Alberta
780.468.2588 (Manus)
780.425.5510 (Mod-U-Blast)

Hamilton, Ontario
905.527.6000 / 888.794.5665

Mississauga, Ontario
905.890.5837

Winnipeg, Manitoba
204.256.3324

WWW.ALLREDI.COM / 800.252.7848

WWW.ALLREDI-CA.COM / 800.661.3842

*Allredi™ and Marco® are registered trademarks of Allredi, LLC.
Mod-U-Blast® is a registered trademark of Allredi Blast & Abrasives Canada, Inc.
All other brand names or marks are used for identification purposes and are trademarks of their respective owners.*

ALLREDI™

Literature #1090166_10/10/2025